

SparkliteLED™

User Manual

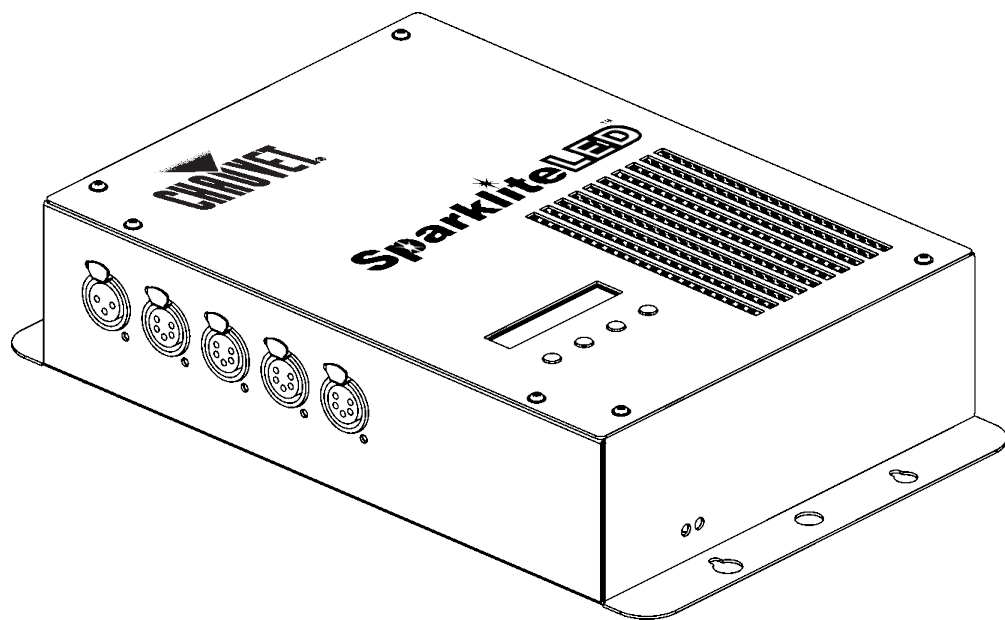































Edition Notes	CHAUVET® released this edition of the SparkliteLED™ User Manual Rev. 02a in April 2010. The SparkliteLED™ User Manual Rev. 02a covers the description, safety precautions, installation, programming and maintenance of the CHAUVET® SparkliteLED™ lighting fixture.																				
Trademarks	CHAUVET® is a registered trademark of CHAUVET & Sons Inc. (d/b/a CHAUVET® or Chauvet). The CHAUVET® logo in its entirety including the Chauvet name and the dotted triangle, and all other trademarks on this manual pertaining to services, products or marketing statements (example: It's Green Thinking™) are owned or licensed by CHAUVET®. Any other product names, logos, brands, company names and other trademarks featured or referred to within this document are the property of their respective trademark holders.																				
Copyright Notice	CHAUVET® owns the content of this user manual in its entirety, including but not limited to pictures, logos, trademarks and resources. © Copyright 2010 CHAUVET® All rights reserved Electronically published by CHAUVET® in the United States of America																				
Manual Usage	CHAUVET® authorizes its customers to download and print this manual for professional information purposes only. CHAUVET® expressly prohibits the usage, copy, storage, distribution, modification or printing of this manual or its content for any other purpose without its written consent.																				
Document Printing	For better results, print this document in color, on letter size paper (8.5 x 11 inches), double sided. If using A4 paper (210 x 297 mm), configure your printer to scale the content of this document to A4 paper.																				
Intended Audience	Any person in charge of installing, operating and/or maintaining the SparkliteLED™ should read the Guide that shipped with it and this manual in their entirety before installing, operating or maintaining this product.																				
Disclaimers	CHAUVET® believes that the information contained in this manual is accurate in all respects. However, CHAUVET® assumes no responsibility for any error or omissions in this document. CHAUVET® reserves the right to revise this document and to make changes from time to time in the content hereof without obligation of CHAUVET® to notify any person or company of such revision or changes. This does not constitute in any way a commitment by CHAUVET® to make such changes. CHAUVET® may issue a revision of this manual or a new edition of it to incorporate such changes.																				
CHAUVET® Publications Hot Line	If you have any comments about the accuracy of this document or general suggestions regarding how we can improve it, please call us at (800) 762-1084 (US callers) or +1-954-929-1115 (international callers), ext. 43. You can download the latest versions of all CHAUVET® products' manuals from www.chauvetlighting.com .																				
Document Revision	The SparkliteLED™ User Manual Rev. 02a supersedes all previous versions of this manual. Please discard any older versions of this manual you may have, whether in printed or electronic format, and replace them with this version.																				
Fixture at a Glance	<table border="1"> <tbody> <tr> <td>Use on Dimmer</td> <td></td> <td>Auto Programs</td> <td></td> </tr> <tr> <td>Outdoor Use</td> <td></td> <td>Auto-ranging Power Supply</td> <td></td> </tr> <tr> <td>Sound Activated</td> <td></td> <td>Replaceable Fuse</td> <td></td> </tr> <tr> <td>DMX</td> <td></td> <td>User Serviceable</td> <td></td> </tr> <tr> <td>Master/Slave</td> <td></td> <td>Duty Cycle</td> <td></td> </tr> </tbody> </table>	Use on Dimmer		Auto Programs		Outdoor Use		Auto-ranging Power Supply		Sound Activated		Replaceable Fuse		DMX		User Serviceable		Master/Slave		Duty Cycle	
Use on Dimmer		Auto Programs																			
Outdoor Use		Auto-ranging Power Supply																			
Sound Activated		Replaceable Fuse																			
DMX		User Serviceable																			
Master/Slave		Duty Cycle																			

TABLE OF CONTENTS

1. Before you Begin	1
WHAT IS INCLUDED	1
<i>Controller</i>	1
<i>Drape (sold separately)</i>	1
UNPACKING INSTRUCTIONS.....	1
TEXT CONVENTIONS.....	1
ICONS	1
SAFETY INSTRUCTIONS.....	2
2. Introduction	3
SYSTEM DESCRIPTION.....	3
<i>Controller Features</i>	3
<i>Drape Features</i>	3
CONNECTIVITY.....	4
<i>DMX 12 Channel Mode</i>	4
<i>DMX 24 Channel Mode</i>	4
<i>SparkliteLED™ Serial Link</i>	4
DMX CHANNEL SUMMARY.....	5
<i>12 Channel Mode</i>	5
<i>24 Channel Mode</i>	5
PRODUCT DIMENSIONS.....	6
<i>SparkliteLED™ Controller</i>	6
<i>SparkliteLED™ Drape</i>	7
<i>SparkliteLED™ Driver Box</i>	7
3. Setup.....	8
AC POWER	8
<i>Fuse Replacement</i>	8
<i>Power Linking</i>	8
FIXTURE LINKING	9
<i>DMX Data Connection</i>	9
<i>SparkliteLED™ Serial Link</i>	10
<i>Master/Slave Fixture Linking</i>	11
MOUNTING	12
<i>Orientation</i>	12
<i>Rigging</i>	12
<i>SparkliteLED™ Controller</i>	12
<i>SparkliteLED™ Drape</i>	12
4. Operating Instructions	13
CONTROL PANEL	13
<i>Navigation Functions</i>	13
<i>Menu Map Description</i>	13
PROGRAMMING PROCEDURE.....	13
<i>12-Channel DMX Mode</i>	13
<i>24-Channel DMX Mode</i>	14
<i>Auto Mode Playing</i>	14
<i>Auto Mode Programming</i>	14
<i>Exiting Auto Mode Programming</i>	16
<i>Master/Slave Mode</i>	16
<i>Settings</i>	16
MENU MAP.....	17
DMX CHANNEL VALUES	18
<i>12-Channel Mode</i>	18
<i>24-Channel Mode</i>	19
5. Technical Information.....	20
GENERAL MAINTENANCE	20
SPARKLITELED™ SERVICE MAINTENANCE GUIDE.....	21
EXPLODED VIEW (CONTROLLER).....	22
EXPLODED VIEW (DRAPE AND DRIVER).....	23
RETURNS PROCEDURE.....	24
CLAIMS	24

CONTACT US.....	24
TECHNICAL SPECIFICATIONS.....	25
6. Appendix.....	26
DMX PRIMER.....	26
<i>The Physical Medium.....</i>	26
<i>The Signals.....</i>	26
<i>The Functions.....</i>	26
DMX CONFIGURATION.....	26
<i>Personalities.....</i>	26
<i>Starting Address.....</i>	26
<i>Assigning Addresses.....</i>	27
<i>DMX Universes.....</i>	27
DMX CONNECTIVITY.....	27
<i>Fixture Location.....</i>	27
<i>Number of Fixtures.....</i>	27
<i>DMX Data Cabling.....</i>	27
<i>Making your Own DMX Cable.....</i>	27
<i>DMX Cable Characteristics.....</i>	27
<i>DMX Cable Connectors.....</i>	28
<i>3-Pin to 5-Pin Conversion Chart.....</i>	28
<i>DMX Connection.....</i>	28
MASTER/SLAVE LINKING.....	29
<i>Master/Slave Connection.....</i>	29
ID ADDRESSING.....	30
<i>Single Row Connection.....</i>	30
<i>Standard Block Connection.....</i>	30
<i>Repeated Row Block Connection.....</i>	30
<i>Other Effects.....</i>	30
SIZING THE CIRCUIT BREAKERS.....	31
<i>Using the Spec Sticker.....</i>	31
<i>Using the Watts/Volts Method.....</i>	31
<i>Considering the Power Factor.....</i>	31
<i>Using the Volt Amps Method.....</i>	31
<i>Selecting the Circuit Breaker.....</i>	31

1. Before you Begin

What is Included

Controller

- SparkliteLED™ Controller
- Power Cord
- Warranty Card
- User Manual

Drape (sold separately)

- SparkliteLED™ Drape (in a road case)
- Drape link cable (50 feet)
- Warranty Card

Unpacking Instructions



Immediately upon receiving the fixture, carefully unpack the carton or the road case, check the contents to ensure that all parts are present, and have been received in good condition. If any parts appear damaged from shipping or the carton itself shows signs of mishandling, notify the shipper immediately. In addition, retain the box or road case and all the packing material for inspection.

In any event, save the carton and all packing material because, in case that you have to return the fixture to the factory, you will have to return it in its original factory box or road case, and packing.

Text Conventions

CONVENTION	MEANING
1~512	A range of values
50/60	A set of mutually exclusive values in the text
[10]	A DIP switch to be configured
<SET>	A key to be pressed on the fixture's control panel
Settings	A menu option that can be selected but not modified
MENU > Settings	A sequence of menu options to be followed
[1~10]	A range of menu values of which one can be selected
Yes/No	A set of mutually exclusive menu options to choose
ON	A value to be entered or selected

Icons

ICONS	MEANING
	This paragraph contains critical installation, configuration or operation information. Failure to comply with this information may render the fixture partially or completely inoperative, cause damage to the fixture or cause harm to the user.
	This paragraph contains important installation or configuration information. Failure to comply with this information may prevent the fixture from functioning correctly.
	This paragraph reminds you of useful, although not critical, information.

Safety Instructions

Please read the following safety instructions carefully because they include important safety information about the installation, usage and maintenance of this product.



There are no user serviceable parts inside the SparkliteLED™ controller or drape(s). Any reference to servicing them you may find from now on in this User Manual will only apply to properly CHAUVET® certified technicians. Do not open the controller or driver housing, or attempt any repairs, unless you are one of those technicians.



In the unlikely event that this fixture may require service, please contact CHAUVET® at (954) 923-3680.

- Keep this manual for future consultation. If you sell the fixture to another user, make sure that they also receive this manual.
- Always make sure that you are connecting the SparkliteLED™ controller to the proper voltage, as per the specifications in this manual or on the controller.
- Always disconnect the SparkliteLED™ controller and drape(s) from the power source before servicing.
- This product is for indoor use only! To prevent risk of fire or shock, do not expose the fixture to rain or moisture.
- Make sure there are no flammable materials close to the SparkliteLED™ controller or drape(s) while operating.
- Always secure the SparkliteLED™ drape(s) to a fastening device using a safety chain. Do the same with the SparkliteLED™ controller if hanging it.
- Maximum ambient temperature (Ta) is 104° F (40° C). Do not operate the fixture at a higher temperature.
- In the event of a serious operating problem, stop using the fixture immediately!
- Never connect the SparkliteLED™ controller to a dimmer pack.
- Make sure the power cord is not crimped or damaged.
- Never disconnect the power cord by pulling or tugging on the cord.
- Avoid direct eye exposure to the light sources while they are on.

Please refer to all applicable local codes and regulations for proper installation of this fixture.

2. Introduction

System Description

The SparkliteLED™ fixture consists of a SparkliteLED™ controller and up to four SparkliteLED™ drapes per controller. The SparkliteLED™ controller ships with no drapes. Therefore, the user will have to order the SparkliteLED™ drapes separately.

The SparkliteLED™ controller has a DMX Input, a DMX Output, a Link Out and four Drape (1-4) connectors. In addition, the SparkliteLED™ controller has a control panel with a two-row LCD display from where the user can set up the controller's operation mode to DMX 12-Channel, DMX 24-Channel or Master/Slave mode as well as configure the auto-programs and select the fixture's settings.

Each SparkliteLED™ drape has an LED driver box that controls eight groups of 16 RGB LEDs each, with a total of 128 LEDs per drape.



Despite having individual outputs for each drape, all four SparkliteLED™ drapes connected to the same SparkliteLED™ controller will show the same colors and effects since they all share the same data.

Controller Features

- 12 or 24-channel DMX control
- Operating modes
 - 12-channel: LED sparking direction control, color mode, color macro, strobe, auto program, On/Off
 - 24-channel: RGB control per LED group
- RGB color mixing with or without DMX controller
- Recall custom programs via master/slave or DMX
- User configurable Auto Programs
- Configurable LED sparking direction and speed
- Configurable LED group sparking overlap time
- Configurable LED minimum and maximum luminosity
- Configurable color sets
- Master/Slave (proprietary serial link)
- Control panel with LCD display
- Static Playing

Drape Features

- 128 ¼ W RGB LEDs, arranged in eight groups of 16 LEDs each
- Fire retardant treatment
- Shipped in a flight case for extra protection

Connectivity

The user can link two or more SparkliteLED™ controllers using one of two connection methods, standard DMX connection or proprietary serial link. However, choosing the connection method depends on the DMX mode selected.

DMX 12 Channel Mode

The DMX 12-Channel mode allows each SparkliteLED™ controller to make their respective SparkliteLED™ drapes to show various preconfigured combinations of colors and intensities as well as specific automatic programs.

When using multiple SparkliteLED™ controllers, the DMX 12 Channel mode can only run if the SparkliteLED™ controllers use the proprietary serial link connection (see below and the Setup chapter for more information on this type of connection).



Select the DMX 12-channel mode for applications in which the SparkliteLED™ will run automatically. In this mode, you will be able to select any of the LED sparking modes and color combinations from a DMX controller.

However, keep in mind that the changes you make from the DMX controller will become active once the current sequence ends, which may take a few seconds.

DMX 24 Channel Mode

The DMX 24-Channel mode allows each SparkliteLED™ controller to determine the RGB color for each of the eight LED groups on the drapes.

When using multiple SparkliteLED™ controllers, the DMX 24 Channel mode can run on any of the two connection modes, standard DMX or proprietary serial link (see below the Setup chapter for more information on these types of connections).

If using the standard DMX connection, each SparkliteLED™ controller can have its own starting address for a more detailed control of the show (see the Appendix chapter for more information on DMX starting address). Alternatively, all the SparkliteLED™ controllers can share the same starting address to provide a synchronized show, which would also require less channels of the DMX controller. However, for synchronized shows, the proprietary serial link provides a faster alternative.



Select the DMX 24-channel mode for applications in which the SparkliteLED™ will run manually from a DMX controller. In this mode, you will be able to select manually each color combination from a DMX controller. These changes will be effective immediately as there is no program running in the background.

However, keep in mind that you will not have access to any preprogrammed function on the SparkliteLED™. Therefore, you will have to create your own chases and scenes on the DMX controller.

SparkliteLED™ Serial Link

The SparkliteLED™ proprietary serial link connection method uses a Master/Slave configuration and a separate signal output (Link Out) on each controller. The first SparkliteLED™ controller in the serial link is the only one seen by the DMX controller. Therefore, this one is the only SparkliteLED™ controller in the group requiring a DMX starting address (see the Appendix chapter for more information on DMX starting address). The other SparkliteLED™ controllers are slaves of the first SparkliteLED™ controller (see the Setup chapter for more information on this type of connection).

The proprietary serial link is the connection method used with the DMX 12-Channel and Master/Slave modes.

DMX Channel Summary

12 Channel Mode

CHANNEL	FUNCTION
1	LED sparkling mode (1~7) or Strobe
2	Color overlap time (Mode 1~7) or strobe frequency (Strobe)
3	Color change speed
4	Minimum LED intensity
5	Maximum LED intensity
6	Static or dynamic color mode (1~4) selection
7	Color 1 selection
8	Color 2 selection
9	Color 3 selection
10	Color 4 selection
11	Program selection (1~8)
12	Drape(s) On/Off

24 Channel Mode

CHANNEL	FUNCTION
1	1 st Group Red Color
2	1 st Group Green Color
3	1 st Group Blue Color
4	2 nd Group Red Color
5	2 nd Group Green Color
6	2 nd Group Blue Color
7	3 rd Group Red Color
8	3 rd Group Green Color
9	3 rd Group Blue Color
10	4 th Group Red Color
11	4 th Group Green Color
12	4 th Group Blue Color
13	5 th Group Red Color
14	5 th Group Green Color
15	5 th Group Blue Color
16	6 th Group Red Color
17	6 th Group Green Color
18	6 th Group Blue Color
19	7 th Group Red Color
20	7 th Group Green Color
21	7 th Group Blue Color
22	8 th Group Red Color
23	8 th Group Green Color
24	8 th Group Blue Color

Product Dimensions

SparkliteLED™ Controller

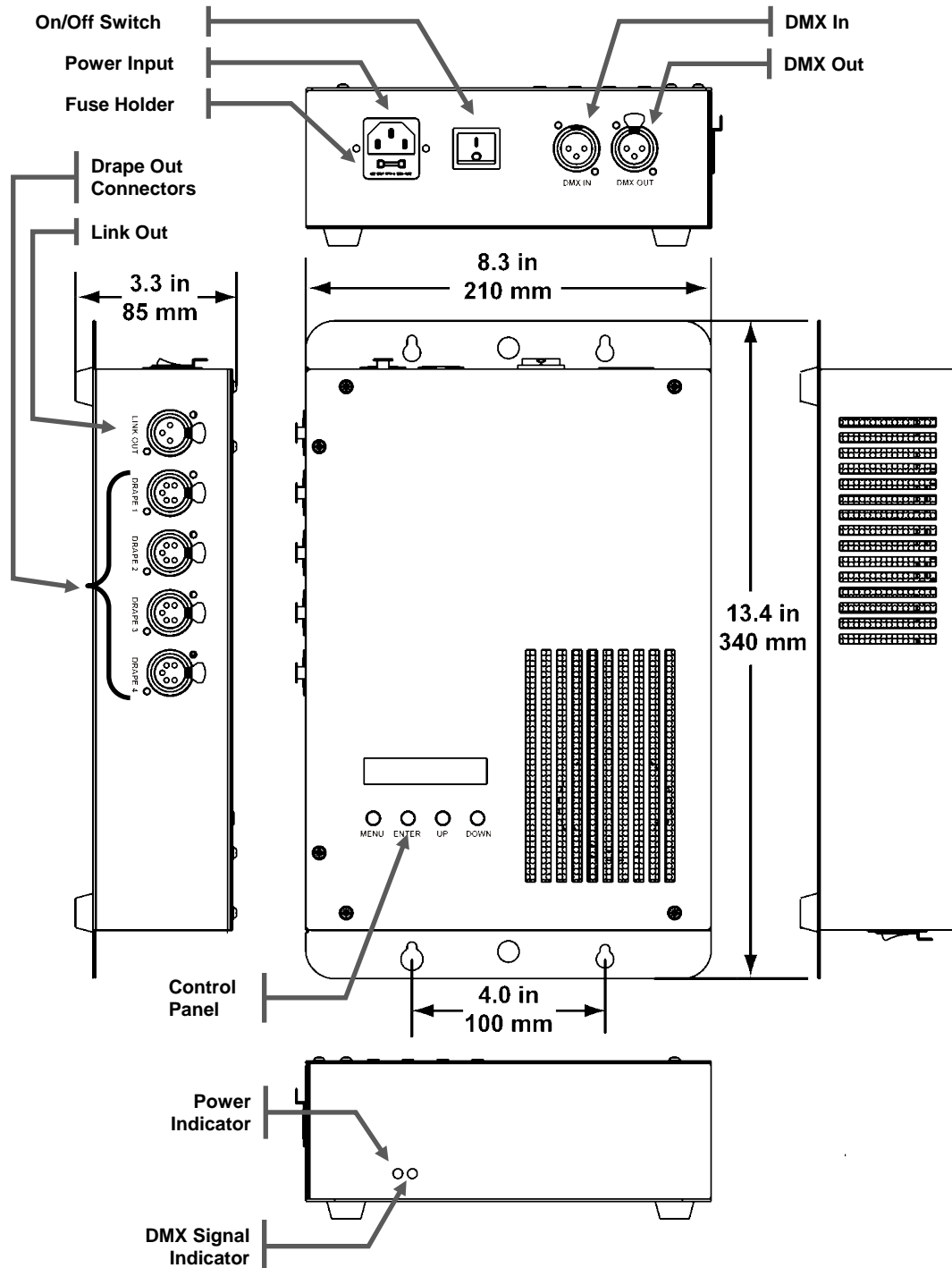

SparkliteLED™ Drape

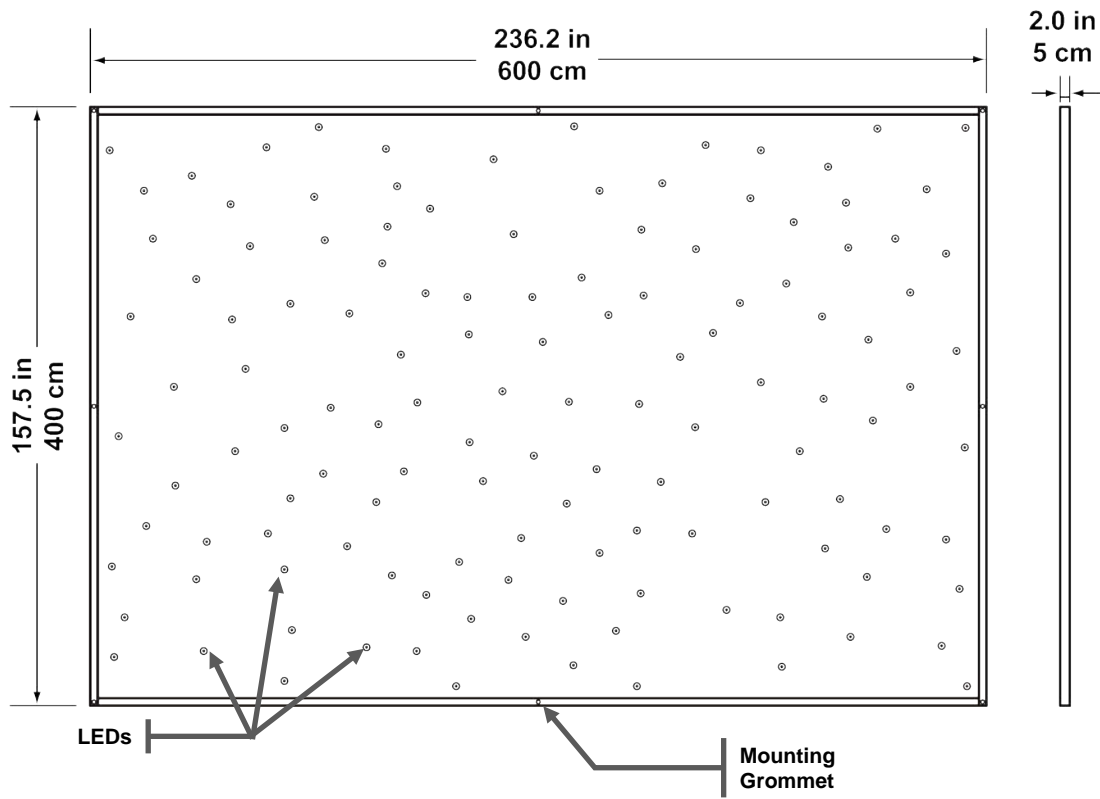

SparkliteLED™ Driver Box

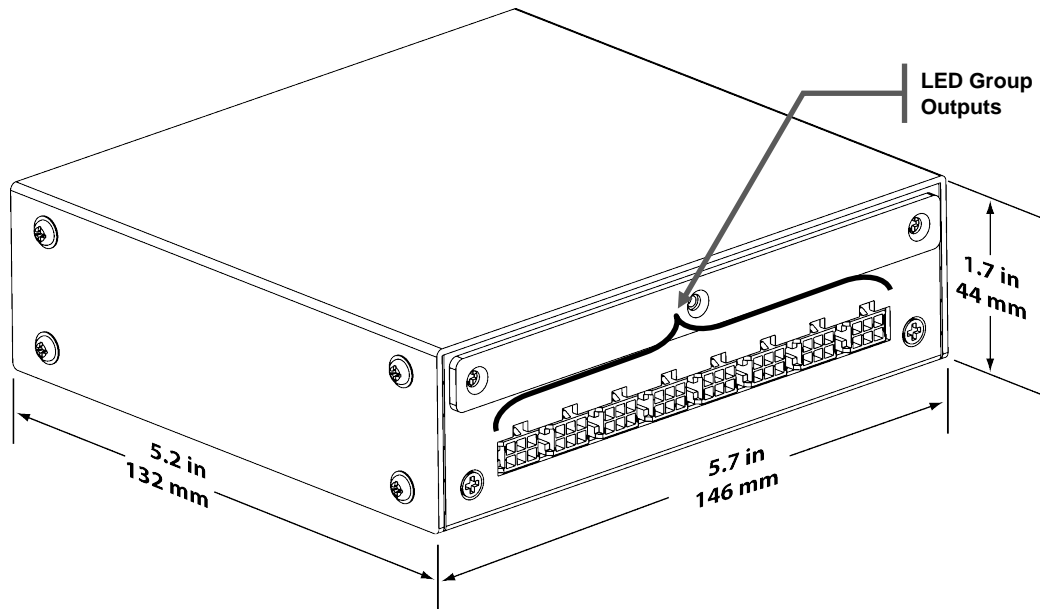

3. Setup

AC Power

This fixture has an auto-sensing power supply that can work with an input voltage range of 100~240 VAC, 50/60 Hz.



Always connect the fixture to a protected circuit with an appropriate electrical ground to avoid the risk of electrocution or fire.

To determine the power requirements for this fixture, see the label affixed to the side of the fixture controller or refer to the fixture's specifications chart. The listed current rating indicates its maximum current draw with all four drapes installed and all LEDs in white color (RGB at 100%). Please refer to the *Sizing the Circuit Breakers* section in the *Appendix* chapter.



Never connect the fixture to a rheostat (variable resistor) or dimmer circuit, even if the rheostat or dimmer channel serves only as a 0 to 100% switch.

Fuse Replacement

- With a flat head screwdriver, wedge the fuse holder out of its housing and remove the blown fuse from its holder.
- Replace the blown fuse with a fuse of the exact same type and rating.
- Insert the fuse holder back in its place, and reconnect power.

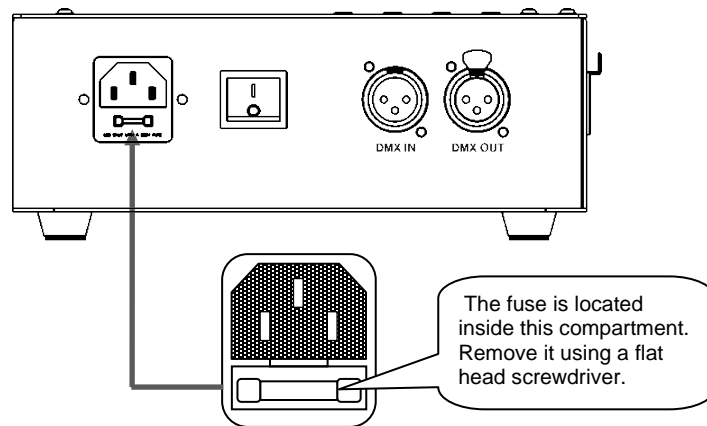

Disconnect the power cord before replacing the fuse and always replace it with a fuse of the same type and rating.

Power Linking

The SparkliteLED™ controller provides no power linking to other units. Therefore, in an installation with more than one SparkliteLED™ controller, you will have to provide power to each unit.

Fixture Linking

The SparkliteLED™ controller can operate in any of two modes, 12-channel or 24-channel. In both cases, the SparkliteLED™ controller links to a DMX controller and other DMX compatible fixtures using DMX links. However, it is important to pay attention to the connection method for each of these modes.



If you are not familiar with the DMX standard, please refer to the Appendix chapter to learn more about it.

DMX Data Connection

The SparkliteLED™ uses the standard DMX data connection for its DMX 24-Channel mode. See the Introduction chapter for a description of the DMX 24-Channel mode and the Operation Instructions chapter to learn how to configure the SparkliteLED™ controller appropriately for this mode.

Procedure

1. Connect the first DMX cable to between the DMX Output connector of the DMX controller and the DMX Input connector of the first SparkliteLED™ controller.
2. Connect the second DMX cable as shown in the figure below.
3. Continue linking the other SparkliteLED™ controllers in the same way.

DMX Data Connection Diagram

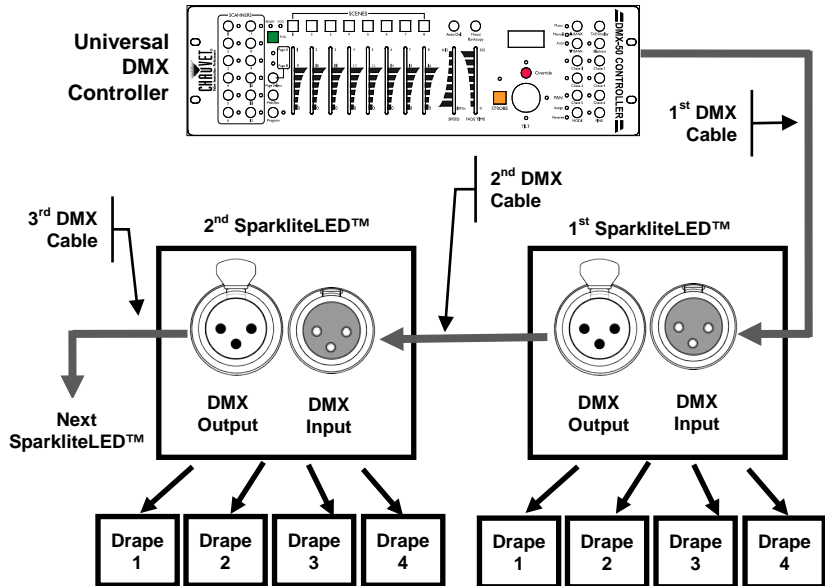

SparkliteLED™ Serial Link

The SparkliteLED™ uses the proprietary serial link (Link Output to DMX Input) for its DMX 12/24 Channel mode. See the *Introduction* chapter for a description of the serial link and the *Operating Instructions* chapter to learn how to configure the SparkliteLED™ controller.

Procedure

1. Connect the first DMX cable to between the DMX Output connector of the DMX controller and the DMX Input connector of the first SparkliteLED™ controller.
2. Connect the second DMX cable as shown in the figure below. Note that you have to use the Link Output connector.
3. Continue linking the other SparkliteLED™ controllers in the same way.

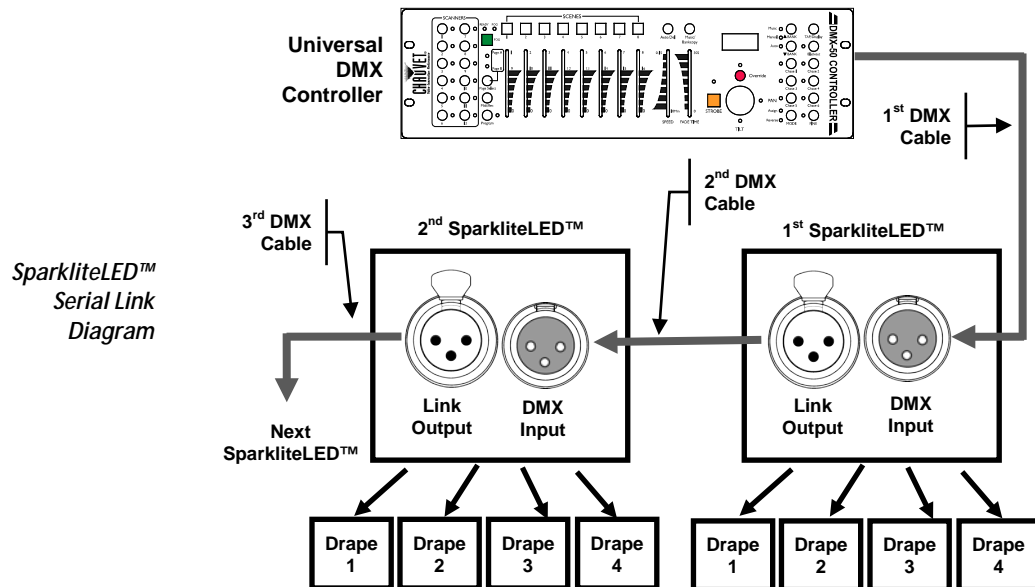

Master/Slave Fixture Linking

The Master/Slave mode allows one SparkliteLED™ controller (the master) running a preconfigured program to control several SparkliteLED™ controllers (the slaves) without requiring a DMX controller. In this mode, the drapes connected to the master and slave SparkliteLED™ controllers will operate in unison.

The SparkliteLED™ uses the serial link (Link Output to DMX Input) for its Master/Slave mode as well.

1. Link the fixtures as indicated in steps 3 to 5 of the previous section.
2. Make sure that there is no DMX controller connected to the daisy chain.
3. Follow the steps indicated in the “Operating Instructions” chapter of this manual to configure the master and the slave fixtures.

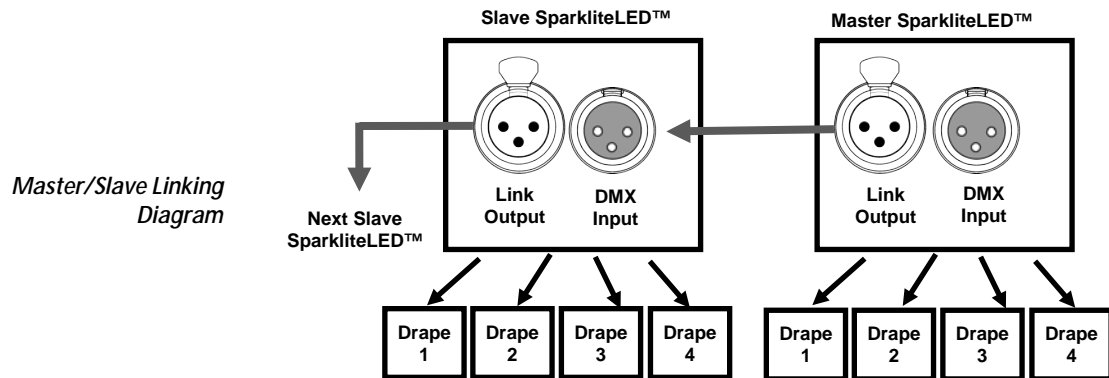

Mounting

Orientation

Always mount this fixture in any safe position while making sure that there is adequate room around it for ventilation.

Rigging

The SparkliteLED™ fixture consists of a controller unit and one to four LED drapes. Each of them has specific rigging specifications. CHAUVET® recommends following the general instructions below for the SparkliteLED™ controller and the SparkliteLED™ drapes.

- When selecting an installation location, consider ease of access to the fixture for operation, programming adjustments and routine maintenance.
- Never mount the fixture in places where rain, high humidity, extreme temperature changes or restricted ventilation may affect it.
- Make sure that the location where you are mounting the fixture can support its weight. Please see the “Technical Specifications” section of this manual for the weight requirement of this fixture.

SparkliteLED™ Controller

You should mount the SparkliteLED™ controller on a flat, dry and rigid surface such as plywood or similar. The SparkliteLED™ controller's base plate has four holes to accommodate regular screws for this purpose, as shown below.

In addition, the base plate has two M10 through holes and a threaded M10 socket to mount the SparkliteLED™ controller onto a truss by using the appropriated type of clamps.

In any case, remember the recommendations indicated above regarding access to the unit and necessary room for ventilation.

SparkliteLED™ Controller
Mounting Diagram

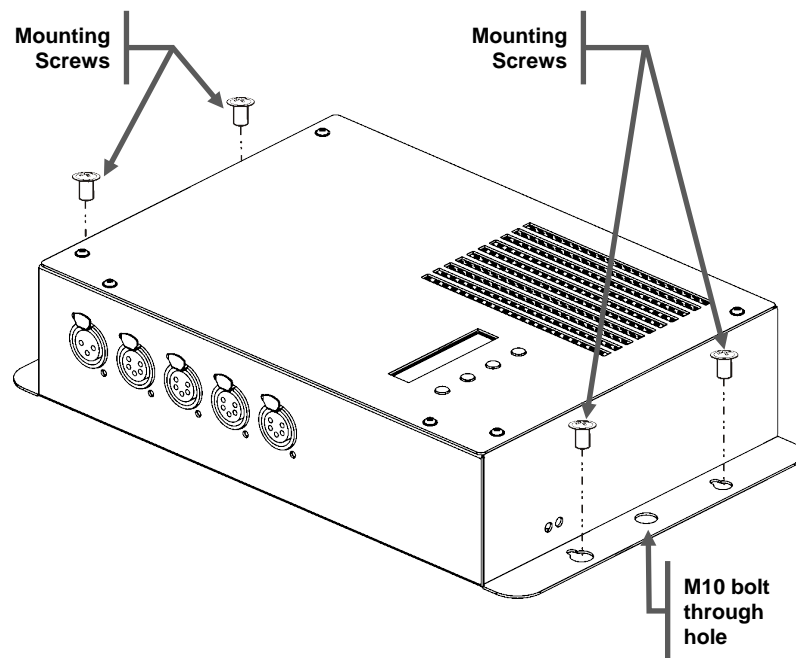

SparkliteLED™ Drape



You should mount each SparkliteLED™ drape hanging from a truss or any other suitable anchoring device using safety steel cables through the mounting grommets on its sides (see diagram below).

Each SparkliteLED™ drape weighs 39.7 lbs (18 Kg) and because of its size, it may be difficult to handle by a single person. Always have someone help you with mounting the SparkliteLED™ drapes.

4. Operating Instructions

Control Panel

The SparkliteLED™ controller has a control panel to configure its functions. You can access these functions by using the four panel buttons located directly under the LCD Display. The table below explains the functions of those buttons.

Button	Function
<MENU>	Used to access the menu or to return to a previous menu option
<ENTER>	Selects a menu option
<UP>	Scrolls through menu options in descending order
<DOWN>	Used to select and store the current menu or option within a menu

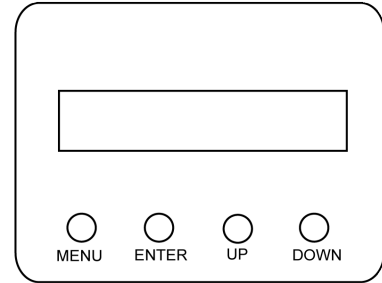

Navigation Functions

The Control Panel LCD Display has two lines. The upper line shows the menu items the user selects from the menu map. While navigating the menu map, only the upper row is active. When the user reaches a menu function that has an option to be accepted or changed, the display will show it on its lower row.

- To move to the right side of the menu map (next level), press <ENTER>. This will serve to accept the current option and move forward.
- To move up or down in the menu map, use <UP> and <DOWN>. This will show the available options for the current menu item.
- To move to the left side of the menu map (previous level), press <MENU>. This will return the display to the previous option or exit the current option without changing its value.

Menu Map Description

The menu map in page 17 shows the various programming levels and the functions they contain. Use the control panel buttons, as shown above, to navigate it.

Programming Procedure

To start programming the SparkliteLED™ controller, the display must show **MENU**.

On power up, **MENU** shows on the display automatically. However, if someone has already configured the SparkliteLED™ controller, its display may be showing the current mode.

If **MENU** does not show on the display, press <MENU> repeatedly until **MENU** appears.

This is the top of the menu map. At this point, <ENTER>, <UP> and <DOWN> will not work.

12-Channel DMX Mode

- With **MENU** showing on the display, press <MENU> once.
The display will show **12CH DMX Mode**.
- Press <ENTER> to select this option.
The lower row of the display will show **[SET] select**.
- Press <ENTER> again to enable the 12-Channel DMX mode.
The display will show **12CH DMX512**, which means that the 12-Channel DMX mode is now active.



If using multiple SparkliteLED™ controllers in the 12CH DMX Mode, remember to connect them using the proprietary serial link, not the standard DMX link.

24-Channel DMX Mode

- With **MENU** showing on the display, press **<MENU>** twice. The display will show **24CH DMX Mode**.
- Press **<ENTER>** to select this option. The second row of the display will show **[SET] select**.
- Press **<ENTER>** again to enable the 24-Channel DMX mode. The display will show **24CH DMX512**, which means that the 24-Channel DMX mode is now active.

Auto Mode Playing

- With **MENU** showing on the display, press **<MENU>** three times. The display will show **Auto**.
- Press **<ENTER>** to select this option. The upper row of the display will show **Program [1]**.
- Alternatively, to select any of the other Auto Programs (2-8), press **<UP>** or **<DOWN>**.
- Press **<ENTER>** again to enable the selected Auto Program. The lower row of the display will show **Edit**. At this point, the SparkliteLED™ controller will play the selected program.
- Press **<MENU>** to leave the selected program running. The display will show the selected program.

Auto Mode Programming

- With the selected program showing on the upper row of the display and **Edit** showing on its lower row, press **<ENTER>** to configure the selected program. The display will show **Pattern type**.
- Press **<ENTER>** to change the pattern type.
- Alternatively, press **<UP>** or **<DOWN>** to select any of the other parameters (*Cross Time, Speed, Minimum, Maximum, Number of Colors* or *Set color 1-4*).

Pattern Type

- LED sparking direction patterns (1-7) or LED Strobe mode
- With the display showing **Pattern type**, press **<ENTER>**. The display will show **MODE (1)**.
 - Alternatively, to select any of the other pattern types (*Mode 2-7* or *Strobe*), press **<UP>** or **<DOWN>**.
 - To activate the selected pattern type, press **<ENTER>**. The display will briefly show **OK select** and it will return to showing **Pattern type**.
 - Press **<DOWN>** to select the next parameter or **<MENU>** to exit to the previous level.

Cross Time

- LED sparking overlap time (Mode 1-7) or strobe frequency (Strobe mode)
- With the display showing **Cross time**, press **<ENTER>**. The display will show the current value (**0-255**).
 - Press **<UP>** or **<DOWN>** to change the value.
 - To activate the selected value, press **<ENTER>**. The display will briefly show **OK select** and it will return to showing **Cross time**.
 - Press **<DOWN>** to select the next parameter or **<MENU>** to exit to the previous level.

Speed

Color change speed

- With the display showing **Speed**, press **<ENTER>**.
The display will show the current value (0~255).
- Press **<UP>** or **<DOWN>** to change the value.
- To activate the selected value, press **<ENTER>**.
The display will briefly show **OK select** and it will return to showing **Speed**.
- Press **<DOWN>** to select the next parameter or **<MENU>** to exit to the previous level.

Minimum

Minimum LED brightness value

- With the display showing **Minimum**, press **<ENTER>**.
The display will show the current value (0~255).
- Press **<UP>** or **<DOWN>** to change the value.
- To activate the selected value, press **<ENTER>**.
The display will briefly show **OK select** and it will return to showing **Minimum**.
- Press **<DOWN>** to select the next parameter or **<MENU>** to exit to the previous level.

Maximum

Maximum LED brightness value

- With the display showing **Maximum**, press **<ENTER>**.
The lower row of display will show the current value (0~255).
- Press **<UP>** or **<DOWN>** to change the value.
- To activate the selected value, press **<ENTER>**.
The display will briefly show **OK select** and it will return to showing **Maximum**.
- Press **<DOWN>** to select the next parameter or **<MENU>** to exit to the previous level.

Number of Colors

Selects the number of colors and the mode (static or dynamic), or all colors (RGB)



Color modes 1~4 are static (one, two, three or four colors, respectively). Color modes 5~7 are dynamic (four, three or two colors, respectively). Color mode 8 is for all colors (RGB).

- With the display showing **Number colors**, press **<ENTER>**.
The lower row of the display will show **1 Color mode**.
- Alternatively, to select any of the other color modes (2~7 Color or Full Color), press **<UP>** or **<DOWN>**.
- To activate the selected color mode, press **<ENTER>**.
The display will briefly show **OK select** and it will return to showing **Number colors**.
- Press **<DOWN>** to select the next parameter or **<MENU>** to exit to the previous level.

Set color (1~4)

Assigns a color to Color 1, Color 2, Color 3 and Color 4, respectively.



When selecting "1 Color" above, only configure Color 1. When selecting "2 Colors" above, only configure Color 1 and Color 2. When selecting "3 Colors" above, configure Color 1~3. When selecting "4 Colors" above, configure Color 1~4. When selecting "Full Color" above, do not configure any color in this step.

- With the display showing **Set color 1~4**, press **<ENTER>**.
The lower row of the display will show the current set color 1~4 value (0~255).
- Press **<UP>** or **<DOWN>** to change the value.
- To activate the selected set color, press **<ENTER>**.
The display will briefly show **OK select** and it will return to showing **Set color 1**.
- Press **<DOWN>** to select the next set color parameter (2, 3, or 4) or **<MENU>** to exit to the previous level.

Exiting Auto Mode Programming

- Once done programming all Auto Mode parameters, press **<MENU>** to back up from the latest parameter.
The upper row of the display will show the current **Program** number, while the lower row will show **[SET] save**.
- Press **<ENTER>** to save the changes to the current program or **<MENU>** to exit without saving.



When you configure the SparkliteLED™ controller to work in Auto Mode, it automatically assumes the “master” function in a Master/Slave connection.

Master/Slave Mode

This mode only applies to the SparkliteLED™ controllers connected behind a SparkliteLED™ controller set as “master” (*Auto Mode*) using the proprietary serial link.

- With **MENU** showing on the display, press **<MENU>** four times.
The upper row of display will show **Slave mode**, while the lower row will show **[SET] select**.
- Press **<ENTER>** to activate the Slave Mode.
The upper row of the display will show **Slave**, while the lower row will briefly show **OK select** and it will clear afterwards.



If using multiple SparkliteLED™ controllers configured in Master/Slave Mode, you must connect them using the proprietary serial link.

Settings

- With **MENU** showing on the display, press **<MENU>** five times.
The display will show **Settings**.
- Press **<ENTER>**.
The display will show **SET DMX address**.
- Alternatively, to select the other setting (*Allow edit PROG*), press **<UP>** or **<DOWN>**.

Starting DMX Address

DMX Address of the first fixture’s DMX channel (See “DMX Primer”)

- With the display showing **SET DMX address**, press **<ENTER>**.
The lower row of the display will show the current starting DMX address (**1~255**).
- Press **<UP>** or **<DOWN>** to change the starting DMX address.
- Press **<ENTER>** to accept the new starting DMX address.
The upper row of the display will show **SET DMX address**, while the lower row will show the current setting (**1~255**).
- To activate the new starting DMX address, press **<ENTER>**.
The display will briefly show **OK save** and it will return to showing **SET DMX address**.
- Press **<DOWN>** to select the other setting parameter (*Allow edit PROG*) or **<MENU>** to exit to the previous level.

Allow Edit PROG

Auto Program modifications enabled/disabled

- With the display showing **Allow edit PROG**, press **<ENTER>**.
The lower row of the display will show **[YES] NO**. The selected option will show between brackets.
- Alternatively, press **<UP>** or **<DOWN>** to change the selected option to **[NO]**.
- To activate the selected option, press **<ENTER>**.
The display will briefly show **OK save** and it will return to showing **Allow edit PROG**.
- Press **<DOWN>** to select the other setting parameter (*Starting DMX address*) or **<MENU>** to exit to the previous level.

Menu Map

1 st Level	2 nd Level	3 rd Level	4 th Level	Description
12CH DMX mode	[SET] select	12CH DMX	N/A	Selects the 12-channel DMX mode
24CH DMX mode	[SET] select	24CH DMX	N/A	Selects the 24-channel DMX mode
Auto	Program 1~8	Pattern type	Mode 1~7	Selects an LED sparking direction
			Strobe mode	Activates the LED strobe mode
		Cross time	0~255	LED spark duration or strobe frequency
		Speed		Color change speed when in Strobe
		Minimum		Minimum LED brightness
		Maximum		Maximum LED brightness
		Number colors	Color mode	Selects the number of colors (1~4), and the color mode (dynamic or static)
			Color flow	Selects all RGB colors
		Set color 1	N/A	Defines Color 1
		Set color 2		Defines Color 2
		Set color 3		Defines Color 3
		Set color 4		Defines Color 4
Slave mode	[SET] select	Slave	N/A	Enables the slave mode
	Allow Edit PROG	YES/No	N/A	Enables Auto Program editing

DMX Channel Values

12-Channel Mode

Channel	Value	Percent/Setting	Function
1	000 ó 031	LED sparking pattern 1	LED sparking pattern
	032 ó 063	LED sparking pattern 2	
	064 ó 091	LED sparking pattern 3	
	092 ó 127	LED sparking pattern 4	
	128 ó 159	LED sparking pattern 5	
	160 ó 191	LED sparking pattern 6	
	192 ó 223	LED sparking pattern 7	
	224 ó 255	Strobe	Strobe mode
2	000 ó 255	0~100%	Overlap time (Mode 1~7 active)
		0~20 Hz	Strobe frequency (Strobe active)
3	000 ó 255	0~100%	Color change speed
4			Min. LED brightness
5			Max. LED brightness
6	000 ó 031	One-Color Static Mode	Color Modes Channel 6 determines the number of colors and the way they will show (static or dynamic), or all RGB colors
	032 ó 063	Two-Color Static Mode	
	064 ó 095	Three-Color Static Mode	
	096 ó 127	Four-Color Static Mode	
	128 ó 159	Four-Color Flow Mode	
	160 ó 191	Three-Color Flow Mode	
	192 ó 223	Two-Color Flow Mode	
	224 ó 255	Full Color (RGB)	
7, 8, 9 & 10	000 ó 009	Red	Color selection Ch 7 selects Color 1 Ch 8 selects Color 2 Ch 9 selects Color 3 Ch 10 selects Color 4
	010 ó 019	Yellow	
	020 ó 029	Green	
	030 ó 039	Cyan	
	040 ó 049	Blue	
	050 ó 059	Purple	
	060 ó 069	White	
	070 ó 079	Orange	
	080 ó 089	Pale green	
	090 ó 099	Deep cyan	
	100 ó 109	Pale blue	
	110 ó 119	Deep pink	
	120 ó 129	Pale purple	
	130 ó 139	Pale pink	
	140 ó 149	Milky green	
	150 ó 159	Milky blue	
	160 ó 169	Milky purple	
	170 ó 179	Sky blue	
	180 ó 189	Milky sky blue	
	190 ó 199	Dawn purple	
	200 ó 209	Morning sky blue	
	210 ó 219	Autumn green	
	220 ó 229	Milky yellow	
230 ó 255	RGB MAX		



- If Ch 6 is in "One-Color Mode," only Color 1 (Ch 7) will show.
- If Ch 6 is in "Two-Color Mode," only Color 1 and 2 (Ch 7 and 8) will show.
- If Ch 6 is in "Three-Color Mode," only Color 1~3 (Ch 7~ 9) will show.
- If Ch 6 is in "Four-Color Mode," Color 1~4 (Ch 7~10) will show.

**12-Channel Mode
(Cont.)**

Channel	Value	Percent/Setting	Function
11	000 ó 010	Reset	Starts and stops the user configured programs
	011 ó 030	Program [1]	
	031 ó 040	Reset	
	041 ó 060	Program [2]	
	061 ó 070	Reset	
	071 ó 090	Program [3]	
	091 ó 100	Reset	
	101 ó 120	Program [4]	
	121 ó 130	Reset	
	131 ó 150	Program [5]	
	151 ó 160	Reset	
	161 ó 180	Program [6]	
	181 ó 190	Reset	
	191 ó 210	Program [7]	
211 ó 220	Reset		
221 ó 255	Program [8]		
12	000 ó 127	OFF	Turns all the LEDs on or off
	128 ó 255	ON	

24-Channel Mode

Channel	Value	Percent/Setting	Function
1	000 ó 255	1st Group Red Color	RGB Color Control (per LED group)
2	000 ó 255	1st Group Green Color	
3	000 ó 255	1st Group Blue Color	
4	000 ó 255	2nd Group Red Color	
5	000 ó 255	2nd Group Green Color	
6	000 ó 255	2nd Group Blue Color	
7	000 ó 255	3rd Group Red Color	
8	000 ó 255	3rd Group Green Color	
9	000 ó 255	3rd Group Blue Color	
10	000 ó 255	4th Group Red Color	
11	000 ó 255	4th Group Green Color	
12	000 ó 255	4th Group Blue Color	
13	000 ó 255	5th Group Red Color	
14	000 ó 255	5th Group Green Color	
15	000 ó 255	5th Group Blue Color	
16	000 ó 255	6th Group Red Color	
17	000 ó 255	6th Group Green Color	
18	000 ó 255	6th Group Blue Color	
19	000 ó 255	7th Group Red Color	
20	000 ó 255	7th Group Green Color	
21	000 ó 255	7th Group Blue Color	
22	000 ó 255	8th Group Red Color	
23	000 ó 255	8th Group Green Color	
24	000 ó 255	8th Group Blue Color	

5. Technical Information

General Maintenance

To maintain optimum performance and minimize wear, the user should clean the fixtures frequently. Usage and environment are contributing factors in determining the cleaning frequency. As a rule, the user should clean the fixtures at least twice a month. Dust build up reduces light output performance and can cause overheating. This can lead to reduced light source life and increased mechanical wear.

For fixtures containing external optical lenses, the user should clean them periodically to optimize light output. The cleaning frequency depends on the environment in which the fixture operates. Damp, smoky or particularly dirty surrounding can cause greater accumulation of dirt on the unit's optics. Even in the cleanest type of surroundings, the user should clean the external optics at least once every 30 days. CHAUVET® recommends cleaning the fixture's external optics with a soft cloth using normal glass cleaning fluid.

To clean a fixture, follow the below recommendations:

- Unplug the fixture from power.
- Wait until the fixture is cold.
- Use a vacuum (or dry compressed air) and a soft brush to remove dust collected on the external vents and reachable internal components.
- Clean all external optics and glass surfaces with a mild solution of glass cleaner or isopropyl alcohol, and a soft, lint free cotton cloth or a lens cleaning tissue.
- Apply the solution directly to the cloth or tissue and drag any dirt and grime to the outside of the lens.
- Gently polish the external glass surfaces until they are free of haze and lint.
- When cleaning movable mirrors, to avoid scratching or damaging their surface, minimize the contact with the mirror surface to a minimum.



Always dry the external optics and glass surfaces carefully after cleaning them.



If the fixture has cooling fans, never spin a fan using compressed air.

SparkliteLED™ Service Maintenance Guide

Symptom	Possible Cause(s)	Possible Action(s)
General low light intensity	<ul style="list-style-type: none"> Dirty LEDs 	<ul style="list-style-type: none"> Clean the SparkliteLED™ drupe regularly
One LED in an LED group failed	<ul style="list-style-type: none"> Faulty (shorted) LED 	<ul style="list-style-type: none"> Replace faulty LED
All the LEDs in a group failed	<ul style="list-style-type: none"> Faulty (open) LED Faulty LED cable Faulty LED driver 	<ul style="list-style-type: none"> Replace faulty LED Replace faulty LED cable Replace faulty LED Driver box
Single SparkliteLED™ controller: All LEDs in a drupe failed	<ul style="list-style-type: none"> Faulty LED driver box Faulty drupe output cable Faulty SparkliteLED™ controller 	<ul style="list-style-type: none"> Replace faulty LED Driver box Repair or replace faulty cable Replace SparkliteLED™ controller
Multiple SparkliteLED™ controllers: All LEDs on a controller failed	<ul style="list-style-type: none"> Faulty SparkliteLED™ controller If using DMX connection, wrong DMX address on the corresponding controller If using proprietary serial link, wrong Master/Slave setting on the corresponding controller SparkliteLED™ controller not powered Faulty DMX cable 	<ul style="list-style-type: none"> Replace SparkliteLED™ controller Set the starting DMX address correctly Set the starting Master/slave mode correctly Check power to the SparkliteLED™ controller Repair or replace faulty cable
Breaker/Fuse keeps blowing	<ul style="list-style-type: none"> Excessive circuit load Short circuit along the power wires 	<ul style="list-style-type: none"> Check total load placed on the electrical circuit Check for a short in the electrical wiring (internal and/or external)
SparkliteLED™ controller does not power up	<ul style="list-style-type: none"> No power Faulty or lose power cord Faulty internal power supply 	<ul style="list-style-type: none"> Check for power on Mains Check power cord Replace internal power supply
Fixture is not responding to DMX	<ul style="list-style-type: none"> Wrong DMX addressing Wrong polarity settings on the controller Lose or damaged DMX or signal patch cables Faulty Main PCB 	<ul style="list-style-type: none"> Check DMX controller and fixture addressing Check polarity switch settings on the controller Check DMX and signal patch cables Replace Display PCB
Loss of signal on some SparkliteLED™ controllers	<ul style="list-style-type: none"> Non compatible signal patch cables Bouncing signals Long cable / Low level signal Too many fixtures Interference from AC wires 	<ul style="list-style-type: none"> Use only compatible DMX and signal patch cables Install terminator as suggested Do not exceed maximum recommended length Install an optically coupled DMX splitter after unit #32. Keep DMX and signal patch cables separated from power cables or black lights



If you still experience technical problems after trying the above solutions, contact CHAUVET® Technical Support.

Exploded View (Controller)

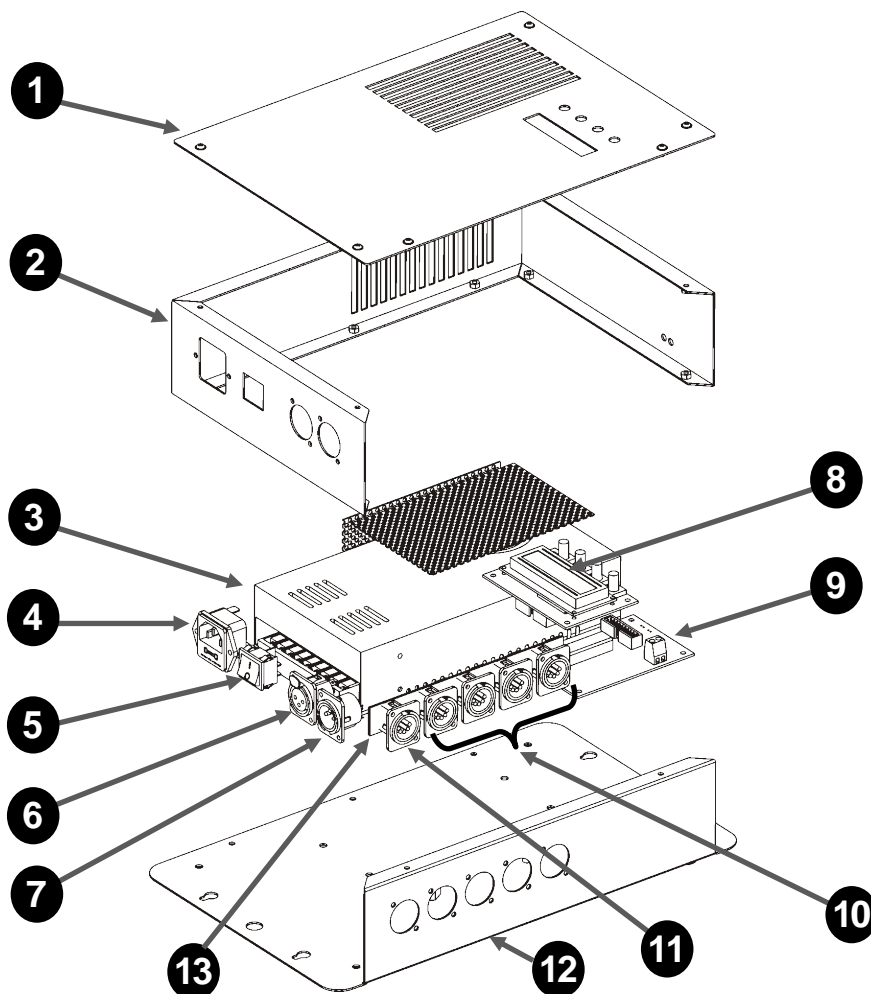

Ref. #	Description	Part Number
1	Top Cover	P100-SKLTPC
2	Side cover	P100-SKLSDC
3	Internal power supply	P140-SKLPOW
4	Power in	P110-IECMALE
5	On/Off switch	P100-SA00013
6	3-Pin XLR Male Socket (DMX Input)	P111-SKLX3M
7 & 11	3-Pin XLR Female Socket (DMX Out & Link Out)	P111-SKLX3F
8	Display PCB	P170-SKLDPLY
9	Main PCB	P170-SKLMAS
10	5-Pin XLR Female Socket (Drape Out)	P111-SKLX5F
12	Back cover	P100-SKLBLC
13	Drape and Serial Link PCB	P111-SKLDSB
Not Shown		
Ref. #	Description	Part Number
N/A	DMX Input and Output PCB	P111-SKLDMX

Exploded View (Drape and Driver)

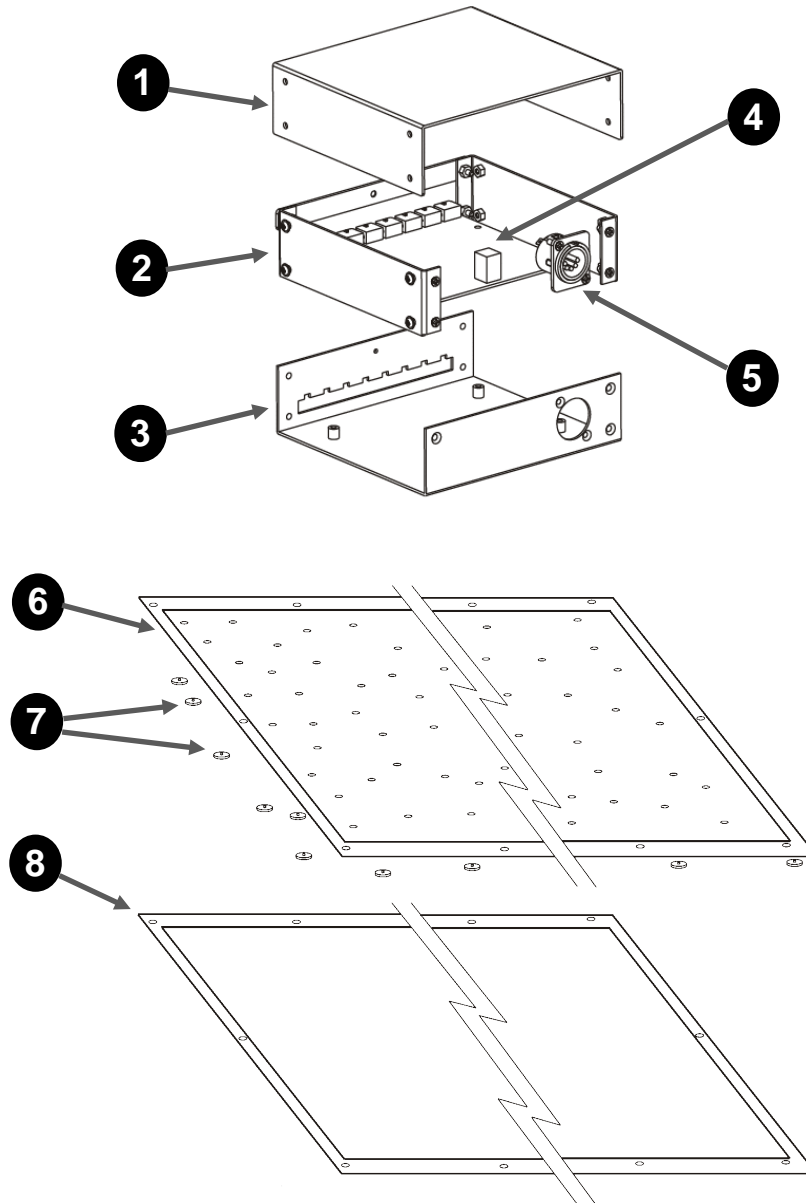

Ref. #	Description	Part Number
1	Driver box cover	P100-SKLDBC
2	Driver box side panels	P100-SKLDBSP
3	Driver box base	P100-SKLDBB
4	Main PCB	P170-SKLDRV
5	5-Pin male XLR connector	P111-SKLX5M
6	Drape front cloth	P100-SKLDFC
7	Single LED PCB	P222-SKLLED
8	Drape back cloth	P100-SKLDBC

Returns Procedure

The user must send the merchandise prepaid and in the original box with its original packing and accessories. CHAUVET® will not issue call tags.

Call CHAUVET® and request a Return Merchandise Authorization Number (RMA #) before shipping the fixture. Be prepared to provide the model number, serial number and a brief description of the cause for the return.

Clearly label the package with the assigned RMA #. CHAUVET® will refuse any product returned without an RMA #.



DO NOT write the RMA # directly on the box. Instead, write it on a properly affixed label.

Once you are given an RMA #, please include the following information on a piece of paper inside the box:

- Your name
- Your address
- Your phone number
- The RMA #
- A brief description of the symptoms

Be sure to pack the fixture properly. Any shipping damage resulting from inadequate packaging is the customer's responsibility. As a suggestion, proper UPS packing or double-boxing is always a safe method to use.



CHAUVET® reserves the right to use its own discretion to repair or replace returned product(s).

Claims

The shipper is responsible for any damage incurred during shipping. Therefore, if the merchandise appears damaged due to shipping, the customer must submit the damage report and any related claims with the carrier, not with CHAUVET®. The customer must submit the report upon reception of the damaged merchandise in a timely manner. Failure to do so may invalidate the customer's claim with the carrier.

For other issues such as missing components or parts, damage not related to shipping, or concealed damage, the customer must make claims to CHAUVET® within seven (7) days of receiving the merchandise.

Contact Us

World Wide

General Information

Chauvet Lighting
 3000 North 29th Court
 Hollywood, FL 33020
 Voice: (954) 929-1115
 Fax: (954) 929-5560
 Toll free: (800) 762-1084

Technical Support

Voice: (954) 929-1115 (Press 4)
 Fax: (954) 929-5560 (Attention: Service)

World Wide Web

www.chauvetlighting.com

It's *Green Thinking*

Technical Specifications

Controller

Length 13.3 in (340 mm)
 Width 3.9 in (100 mm)
 Height 3.3 in (85 mm)
 Weight 8.8 lbs (4.0 kg)

Drape

Length 236.2 in (600 cm)
 Width 157.4 in (400 cm)
 Thickness 1.9 in (5 cm)
 Weight 39.6 lbs (18.0 kg)

Power

Auto-range internal power supply 100~240 VAC, 50/60 Hz
 Fuse F 5 A, 250 V (5 x 20 mm)
 Power Consumption @ 120 VAC, 60 Hz 106 VA (0.9 A) max
 Power Consumption @ 230 VAC, 50 Hz 177 VA (0.8 A) max

Light Source

LED (per drape) 128 RGB, ¼ W, 5 mm diameter, 100,000 hrs

Controller cooling

Cooling system Fan (inside power supply)
 Maximum operating temperature 104° F (40° C)

Drape Fire Resistance Treatment

Fire retardant type FR-1 (non-toxic)
 Fire retardant duration 10 dry cleaning procedures
 Standard compliance NFPA 701 Small Scale
 Other regulatory approvals State of California, BFD, NYPA, CoMA

Control & Programming

DMX input Locking 3-pin XLR male socket
 DMX output Locking 3-pin XLR female socket
 DMX pin configuration Pin 1 shield, pin 2 (-), pin 3 (+)
 Serial Link Out Locking 3-pin XLR female socket
 Drape Out Locking 5-pin XLR female socket
 Protocols USITT DMX512-A
 Proprietary serial link
 DMX Channels User Configurable: 12 or 24 channels

Ordering Information

SparkliteLED™ Controller SPARKLITELEDCON
 SparkliteLED™ Drape SPARKLITELEDDRAPE

WARRANTY INFORMATION

Warranty 2-year limited warranty

6. Appendix

DMX Primer

The DMX protocol (USITT DMX512-A) is a networking protocol that enables a universal DMX controller device to control the features of multiple DMX compatible fixtures, whether par cans, wash lights, moving heads, followspots, foggers, proprietary fixture controllers, etc.

As any other networking protocol, the USITT DMX512-A describes the physical medium, the signals and the functions they control.

The Physical Medium

The DMX controller connects to its associated DMX compatible fixtures using a DMX connection. This connection consists of a series of jumps between the DMX controller and the various DMX compatible fixtures, also known as a daisy chain connection. In this type of connection, the DATA OUT of one fixture or the DMX controller connects to the DATA IN of the next fixture, and so on.

Each DMX fixture links to the previous and next DMX fixture or controller using a DMX cable. This type of cable consists of a section of shielded, two-conductor twisted pair cable with one 3-pin XLR male connector on one end and a 3-pin XLR female connector on the other end. The XLR connectors pin-out is as follows: pin 1 is the *Common* (shield), pin 2 is *Signal Negative* (S-) and pin 3 is *Signal Positive* (S+).

The Signals

The DMX signal stream is unidirectional, from the DMX controller to the DMX compatible fixtures. These signals conform to the EIA-485 standard.

The stream of DMX signals consists of 512 individual, sequential channels that form a frame. The DMX controller constantly sends frames of DMX signals to the DMX connection, even if not all of the 512 channels are in use. Because of this constant transmission method, there can be only one DMX controller in a DMX connection. Otherwise, the DMX signals sent by one controller would interfere with the signals sent by the other controller(s).

The Functions

Each DMX channel can have any unitary value in the 000-255 range. Each DMX compatible fixture uses as many consecutive DMX channels as features the user can control. The sequential numbers assigned to each DMX channel (1-512) are also known as DMX addresses.

The function each DMX channel has and the results of assigning a value to each depend on each controlled fixture. Some fixtures only use a single DMX channel, while others may require 15 or more DMX channels to control all their functions.

DMX Configuration

The DMX fixture configuration consists in determining how many channels each fixture will need as well as assigning the corresponding DMX channels to each fixture in order to size correctly the DMX controller.

Personalities

Most DMX fixtures use multiple personalities, each of them requiring a different number of channels, depending on the number of features it enables. The number of DMX channels used by a fixture may vary from only one (usually the general dimmer control) to 15 or more, as mentioned above.

When the job does not require using all the fixture's capabilities, the user can select a more basic personality (less channels), thus allowing the DMX controller to accommodate more DMX fixtures.

Starting Address

For the DMX controller to control each DMX fixture, the user must first configure each fixture's personality. This will determine the number of required channels to control the fixture. Each channel will have a DMX address assigned to it. However, since assigning a particular DMX address to each channel is impractical, the user will only need to configure on each fixture the DMX address that corresponds to the fixture's Channel 1. This is the fixture's starting address. The fixture will automatically assign the other channels to the subsequent DMX addresses.

Once this assignment is complete, and based on the number of channels it uses, the fixture will respond to the DMX signals sent to the range of DMX channels that begins with the starting address.

For example, a fixture that uses six DMX channels and whose starting address is 100, will accept DMX data sent by the DMX controller to channels 100, 101, 102, 103, 104, and 105.

DMX Configuration (Cont.)

Assigning Addresses

The user must carefully assign the starting addresses for each individual fixture to avoid DMX channel overlapping. If the DMX channels do overlap, the affected fixtures could operate erratically.

However, the user may decide to configure two or more similar fixtures with the same personality and starting address. In this case, all the fixtures with the same starting address will operate in unison.

DMX Universes

A DMX universe is the set of DMX compatible fixtures connected to the same DMX daisy chain, which are receiving DMX data from the same DMX controller using the same set of 512 DMX channels.

Although in most cases an installation will consist of only one DMX universe, it could be necessary to define two or more universes because of constraints imposed by the distance or the number of features.

Most DMX controllers support only one universe, although some DMX controllers may support two or more universes. Each universe will have its own separated DMX daisy chain. A DMX compatible fixture can only be part of a single DMX universe.

DMX Connectivity

Connecting the DMX fixtures to a DMX controller in small to medium installations is usually a rather simple operation that requires a minimum of tools and some planning (not including the actual fixture rigging and configuration).

However, in large installations it may be necessary to plan carefully the position and cabling of each fixture to avoid unexpected problems.

Fixture Location

The order in which the fixtures connect to the DMX controller is not important and it has no effect on how a controller communicates to each fixture. However, the user should always define a physical location for the fixtures that provides for the easiest and most direct cabling to the controller and other fixtures.

Number of Fixtures

When using a DMX controller, the combined number of channels required by all the fixtures on the serial data link determines the number of fixtures the DMX controller has to support. Conversely, the number of onboard sliders, page buttons and fixture buttons limits the number of discrete DMX channels a DMX controller can support.

To comply with the EIA-485 standard, which is the base for the USITT DMX512-A protocol, do not connect more than 32 fixtures without using a DMX optically-isolated splitter. Doing otherwise may result in deterioration of the digital DMX signal.

DMX Data Cabling

You must use DMX compliant data cables to link two or more DMX compatible fixtures. You may purchase CHAUVET® certified DMX cables directly from a dealer/distributor or construct your own cable.

USITT recommends limiting the total length of the DMX cable (from the first fixture/controller to the last fixture) to 300~455 m (985~1,500 ft).

Making your Own DMX Cable

If you choose to create your own DMX cable, make sure to use data-grade cables that can carry a high frequency signal and are less prone to electromagnetic interference. Use a Belden® 9841 or equivalent cable, which meets the specifications for EIA RS-485 applications.

Do not use standard microphone cables for DMX applications because they cannot transmit DMX data reliably over long distances.

DMX Cable Characteristics

The DMX data cable must have the following characteristics:

Type:	<i>shielded, 2-conductor twisted pair</i>
Maximum capacitance between conductors:	30 pF/ft
Maximum capacitance between conductor and shield:	55 pF/ft
Maximum resistance:	20 ohms/1000 ft
Nominal impedance:	100~140 ohms

DMX Connectivity (Cont.)

DMX Cable Connectors

Each DMX cable must have a male, 3-pin XLR connector on one end and a female, 3-pin XLR connector on the other end.

DMX Connector Configuration

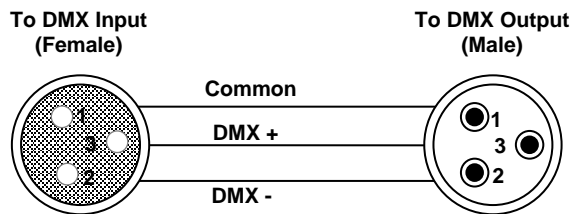

To avoid signal transmission problems and interference, it is always advisable to connect a DMX signal terminator, as seen below.

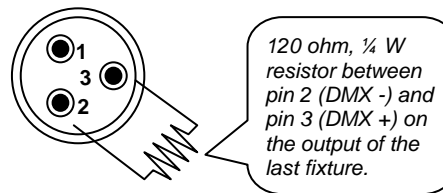

Test all DMX cables with an ohmmeter to verify their correct polarity and to make sure that there are no short-circuits between any of the pins, or between any pin and ground.

If the Common wire (shield) touched the chassis ground, a ground loop could form, which may cause the fixture to perform erratically.

3-Pin to 5-Pin Conversion Chart

If you use a DMX controller or fixture with a 5-pin DMX connector, you will need to use a 5-pin to 3-pin adapter. The chart below details a proper cable conversion.

3-Pin to 5-Pin Conversion Chart

Conductor	3-Pin Female (Output)	5-Pin Male (Input)
Ground/Shield	Pin 1	Pin 1
Negative (-) signal	Pin 2	Pin 2
Positive (+) signal	Pin 3	Pin 3
Not Used		Pin 4
Not Used		Pin 5

DMX Connection

Make sure that the fixtures with which you are working can operate in DMX mode, not in a proprietary connection mode. Refer to the fixtures' manual to learn how to enable their respective DMX modes.

The procedure below illustrates a possible DMX connection method.

- 1) Connect the 3-pin, male connector of the first DMX cable to the DMX Output connector (3-pin, female) of the DMX controller.
- 2) Connect the 3-pin, female connector of the first DMX cable coming from the controller to the DMX Input connector (3-pin, male) of the first DMX fixture.
- 3) Connect the 3-pin, male connector of the second DMX cable to the DMX Output connector (3-pin, female) of the first DMX fixture.
- 4) Connect the 3-pin, female connector of the second DMX cable coming from the first DMX fixture to the DMX Input connector of the second DMX compatible fixture.
- 5) Continue linking the other DMX fixtures in the same way.

DMX Connectivity (Cont.)

The figure below is only an example of a possible DMX serial connection.

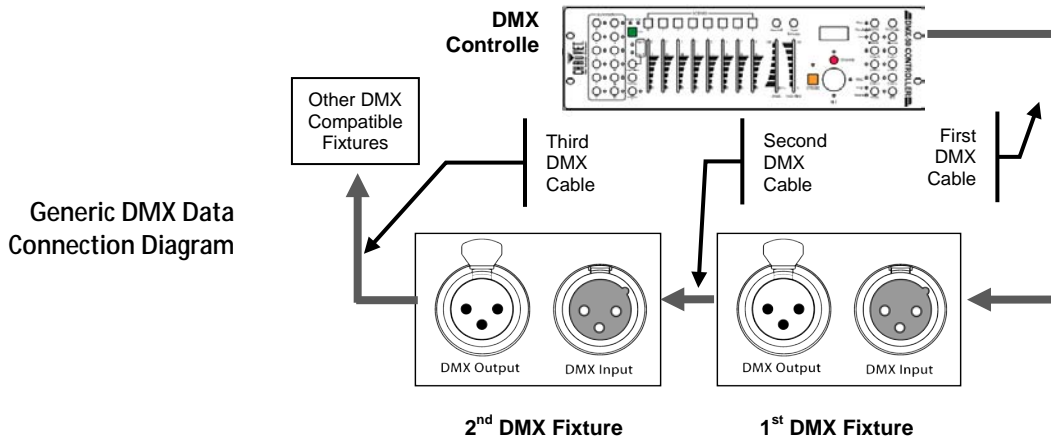

Master/Slave Linking

The Master/Slave mode allows one fixture (the master) to run a preconfigured program to control several other fixtures of the same model (the slaves) without requiring a DMX controller. In this mode, all the slave fixtures will operate in unison with the master fixture.

If a fixture supports the Master/Slave mode, it will have some sort of programming function to configure it as master or slave. Those fixtures that only support DMX mode cannot operate in Master/Slave mode.

Master/Slave Connection

Make sure the fixtures with which you are working are capable of operating in Master/Slave mode. When working in Master/Slave mode, most fixtures use the DMX data connection as well. The difference in this case is that there is no DMX controller involved. Refer to the fixtures' manual to learn how to configure them to work in Master/Slave mode.

The procedure below illustrates a possible connection method.

- 1) Connect the 3-pin, male connector of the first DMX cable to the DMX Output connector (3-pin, female) of the master fixture.
- 2) Connect the 3-pin, female connector of the first DMX cable coming from the master fixture to the DMX Input connector (3-pin, male) of the first slave fixture.
- 3) Connect the 3-pin, male connector of the second DMX cable to the DMX Output connector (3-pin, female) of the first slave fixture.
- 4) Connect the 3-pin, female connector of the second DMX cable coming from the first slave fixture to the DMX Input connector (3-pin, male) of the second slave fixture.
- 5) Continue linking the other slave fixtures in the same way.
- 6) Follow the steps in fixtures' manual to configure the fixtures as master and slaves.

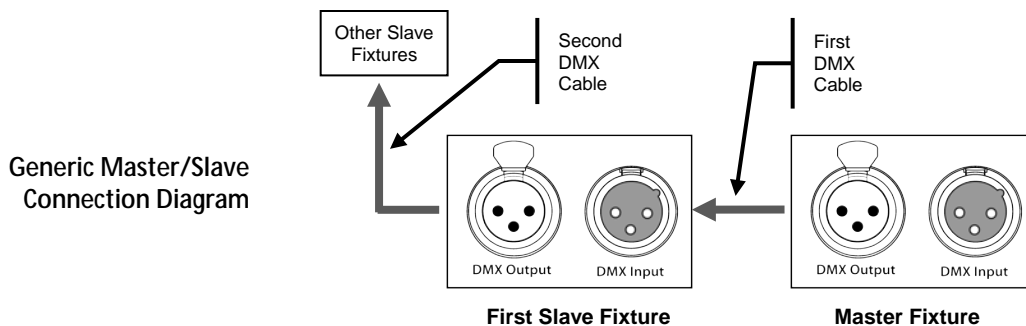

ID Addressing

ID Addressing is a sub-addressing method by which each fixture, apart from its starting address, can also have an “ID” address in the 1–66 range. This allows users to multiply the number of fixtures they can control with a single DMX controller.

Many fixtures have at least one DMX personality or mode that enables ID addressing. In this case, one of the channels of such DMX mode is in charge of selecting an ID address. When using ID addressing, setting the value of the ID addressing channel to “0” allows for the simultaneous control of all the fixtures with the same starting address, regardless of their particular ID address.

ID addressing is also a tool for creating special lighting effects by having several fixtures sharing the same starting DMX address and ID address, as indicated below.

Single Row Connection

The figure below shows a simple DMX layout that uses four fixtures, all with the same DMX address and a unique ID address for each fixture. This allows the user to control simultaneously the whole group of units at that DMX address by setting the ID Addressing channel to 0. Similarly, the user can control each fixture at that DMX address independently by first selecting the DMX address and then using the ID Addressing channel to locate the target ID address.

Single Row ID Addressing Diagram

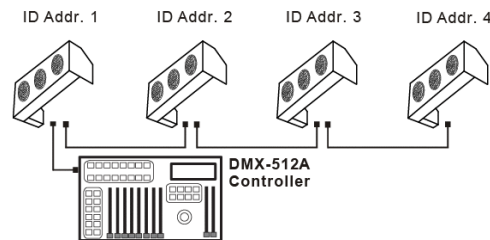

Standard Block Connection

In the Standard Block connection, the fixtures appear in repeated rows of the same length to form a block. For instance, three rows of fixtures with three fixtures per row to form a 3 x 3 block. Each of the fixtures has unique, sequential ascending ID addresses for the controller to control each fixture individually.

Repeated Row Block Connection

In this type of connection, the fixtures appear in repeated rows or columns of the same length to form a block. For instance, there may be three columns of fixtures with three fixtures per column to form a 3 x 3 block. In this case, the fixtures form groups, each with its own sequential ascending ID addresses. This way, the controller will control each group of fixtures individually.

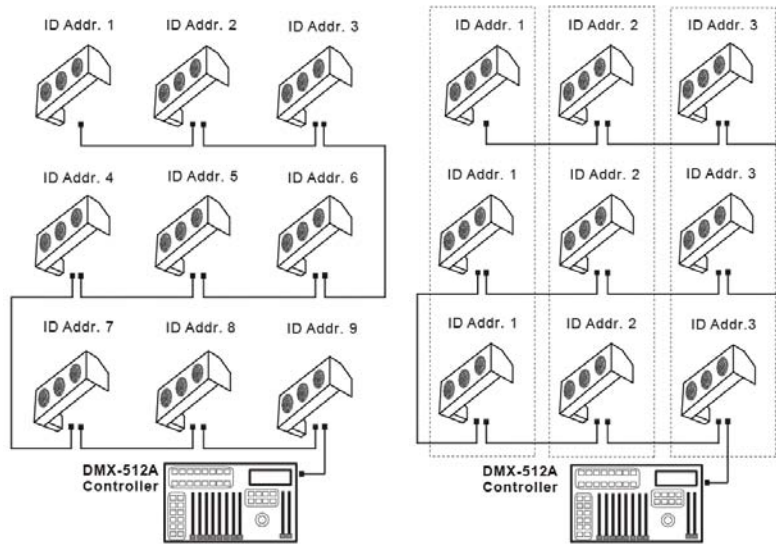

Standard Block Connection

Repeated Block Connection

Other Effects

For other types of effects, you may group the fixtures in diagonal lines or place them in random positions within a single block.

Sizing the Circuit Breakers

Calculating the total current drawn by the fixtures connected to a particular circuit is not complicated if the installer has the right information at hand and knows how to interpret it.

With the fixture's current draw information, the installer can calculate and select the right circuit breaker size (rating) to which they can connect a group of fixtures.

Using the Spec Sticker

CHAUVET® fixtures come with a sticker that indicates the current they consume in a circuit at the specified voltage. This greatly simplifies calculating the total current drawn.

For instance, if the sticker on the fixture indicates, "0.1 A @ 115 VAC, 60 Hz" and the installer is connecting 12 of them on the same 115 VAC circuit, to determine the total current required by the fixtures it would be enough to do this simple calculation:

$$0.1 \text{ A} \times 12 = 1.2 \text{ A}$$

Using the Watts/Volts Method

Some installers may prefer to determine the current drawn by the fixture by dividing its power consumption, indicated in watts (W), by the voltage (V) on the circuit. As an example, assuming that a certain fixture consumes 240 W and it is connected to a 120 VAC circuit, the current it draws would be:

$$240 \text{ W} / 120 \text{ V} = 2 \text{ A}$$

Considering the Power Factor

The above method is accurate only with fixtures whose power factor (PF) is equal, or very close, to "1." Otherwise, the calculated current may be too low with respect to the actual current drawn by the fixture.

In fact, as the PF decreases, the difference between the current calculated using the watts/volts method and the actual current increases.

Therefore, for fixtures with a PF below "0.9," the installer must always consider the fixture's PF when using the watts figure to calculate the current it draws.

For the above example, if the published fixture's PF were "0.7", the resulting drawn current would be as follows:

$$2 \text{ A} / 0.7 = 2.8571 \text{ A}$$

This is approximately equal (\approx) to 2.86 A, 2.9 A, or even 3 A, depending on the installer's desire for accuracy. In other words, the actual current ended up being close to 50% higher than originally calculated.

Using the Volt Amps Method

If the fixture's sticker indicates the power consumption in "volt amps" (VA), the calculation of the drawn current is simply the result of dividing the amount in VA by the voltage on the circuit (V). For a fixture with a consumption of 360 VA, the calculation would be as follows:

$$360 \text{ VA} / 120 \text{ V} = 3 \text{ A}$$

Note that when the power consumption is in VA, the fixture's PF is never part of the current draw calculation.

Selecting the Circuit Breaker

The National Electric Code (NEC) determines that circuit breakers should handle 80% of their rated capacity for continuous loads (those being on for three or more hours) and 100% for intermittent loads. For safety reasons, CHAUVET® recommends assuming that all loads are continuous.

After calculating the total current the fixtures connected to a particular circuit will draw, the installer must consider the 80% rule indicated above. For a total current of 22 A, the calculation is as follows:

$$22 \text{ A} * 1.25 = 27.5 \text{ A}$$

The installer should use a 30 A CB because the immediately lower CB rating, 25 A, would not be enough for this load.

CHAUVET®

3000 N 29th Ct,
Hollywood, FL 33020 U.S.A.
(800) 762-1084 – (954) 929-1115
FAX (954) 929-5560
www.chauvetlighting.com

SparkliteLED™ User Manual Rev. 02a
April 2010

