

LED PAR 64-36VWB
LED PAR 64-36VWC

Snapshot

Use on Dimmer	⊘
Outdoor Use	⊘
Sound Activated	✓
DMX	✓
Master/Slave	✓
Auto-ranging Power Supply	✓
Replaceable Fuse	✓
User Serviceable	⊘
Duty Cycle	⊘

User Manual

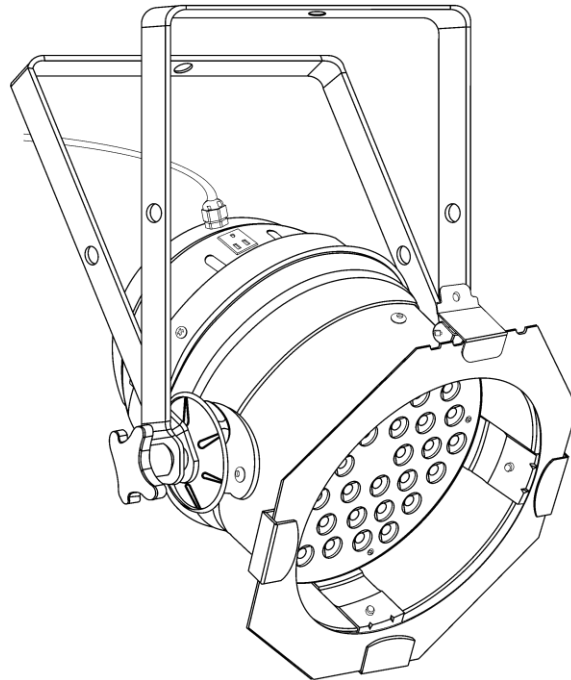

3000 N 29th Ct, Hollywood, FL 33020 U.S.A.
(800) 762-1084 – (954) 929-1115
FAX (954) 929-5560
www.chauvetlighting.com

TABLE OF CONTENTS

1. BEFORE YOU BEGIN	3
WHAT IS INCLUDED	3
UNPACKING INSTRUCTIONS	3
MANUAL CONVENTIONS	3
ICONS	3
SAFETY INSTRUCTIONS	4
2. INTRODUCTION	5
FEATURES	5
<i>Additional Features</i>	5
PRODUCT OVERVIEW	5
PHOTOMETRICS	6
PRODUCT OVERVIEW	7
3. SETUP	8
AC POWER	8
<i>Power Linking</i>	8
MOUNTING	9
<i>Orientation</i>	9
<i>Rigging</i>	9
FIXTURE LINKING	10
<i>Data Cabling</i>	10
<i>DMX Data Cable</i>	10
<i>Cable Connectors</i>	10
<i>3-Pin to 5-Pin Conversion Chart</i>	11
<i>Setting up a DMX Serial Data Link</i>	11
4. OPERATING INSTRUCTIONS	12
CONFIGURING THE STARTING ADDRESS	12
CONTROL PANEL FUNCTIONS	12
MENU MAP	13
DMX OPERATION	13
MASTER/SLAVE	13
STANDALONE OPERATION	14
<i>Automatic</i>	14
<i>Sound-Active</i>	14
<i>Preset Colors</i>	14
<i>Custom Static Color Mixing</i>	14
FIXTURE LINKING	15
DMX CHANNEL VALUES	15
<i>4-CH</i>	15
<i>2-CH</i>	15
SETTING THE STARTING ADDRESS	16
GENERAL TROUBLESHOOTING	16
CONTACT US	16
5. APPENDIX	17
DMX PRIMER	17
GENERAL MAINTENANCE	17
RETURNS PROCEDURE	18
CLAIMS	18
TECHNICAL SPECIFICATIONS	19

1. BEFORE YOU BEGIN

What is included

- 1 x LED PAR 64-36VW B/C
- 1 x Gel Frame
- 1 x Warranty Card
- 1 x User Manual

Unpacking Instructions

Immediately upon receiving a fixture, carefully unpack the carton, check the contents to ensure that all parts are present, and have been received in good condition. Notify the shipper immediately and retain packing material for inspection if any parts appear damaged from shipping or the carton itself shows signs of mishandling. Save the carton and all packing materials. In the event that a fixture must be returned to the factory, it is important that the fixture be returned in the original factory box and packing.



Manual Conventions

CHAUVET® manuals use the following conventions to differentiate certain types of information from the regular text.

CONVENTION	MEANING
[10]	A DIP switch to be configured
<Menu>	A key to be pressed on the fixture's control panel
1~512	A range of values
50/60	A set of values of which only one can be chosen
Settings	A menu option not to be modified (for example, showing the operating mode/current status)
MENU > Settings	A sequence of menu options to be followed
ON	A value to be entered or selected

Icons

This manual uses the following icons to indicate information that requires special attention on the part of the user.

ICONS	MEANING
	This paragraph contains critical installation, configuration or operation information. Failure to comply with this information may render the fixture partially or completely inoperative, cause damage to the fixture or cause harm to the user.
	This paragraph contains important installation or configuration information. Failure to comply with this information may prevent the fixture from functioning correctly.
	This paragraph reminds you of useful, although not critical, information.

Safety Instructions



Please read these instructions carefully. It includes important information about the installation, usage and maintenance of this product.

- Please keep this User Manual for future consultation. If you sell the unit to another user, be sure that they also receive this instruction booklet.
- Always make sure that you are connecting to the proper voltage, and that the line voltage you are connecting to is not higher than that stated on the decal or rear panel of the fixture.
- This product is intended for indoor use only! To prevent risk of fire or shock, do not expose fixture to rain or moisture.
- Make sure there are no flammable materials close to the unit while operating.
- The unit must be installed in a location with adequate ventilation, at least 20 in (50 cm) from adjacent surfaces. Be sure that no ventilation slots are blocked.
- Always disconnect from power source before servicing or replacing fuse and be sure to replace with same fuse source.
- Secure fixture to fastening device using a safety chain.
- Maximum ambient temperature (Ta) is 104° F (40° C). Do not operate fixture at temperatures higher than this.
- In the event of a serious operating problem, stop using the unit immediately. Never try to repair the unit by yourself. Repairs carried out by unskilled people can lead to damage or malfunction. Please contact the nearest authorized technical assistance center.
- Never connect the device to a dimmer pack.
- Make sure the power cord is never crimped or damaged.
- Never disconnect the power cord by pulling or tugging on the cord.
- Never carry the fixture directly from the cord. Always use the hanging/mounting bracket.
- Avoid direct eye exposure to the light source while it is on.

2. INTRODUCTION

Features

- 2 or 4-channel DMX-512 variable white LED PAR can
- Operating modes:
 - 2-channel: warm white, cool white
 - 4-channel: warm white, cool white, strobe rate, dimmer

Additional Features

- Built-in automated programs via master/slave with variable speed
- Built-in sound activated programs via master/slave
- Static color mixing without DMX controller
- Available in black or chrome
- High-power, 1 W, 350 mA LEDs
- Additional power output: max 8 units
- Double-bracket yoke doubles as floor stand
- Includes gel frame

Product Overview

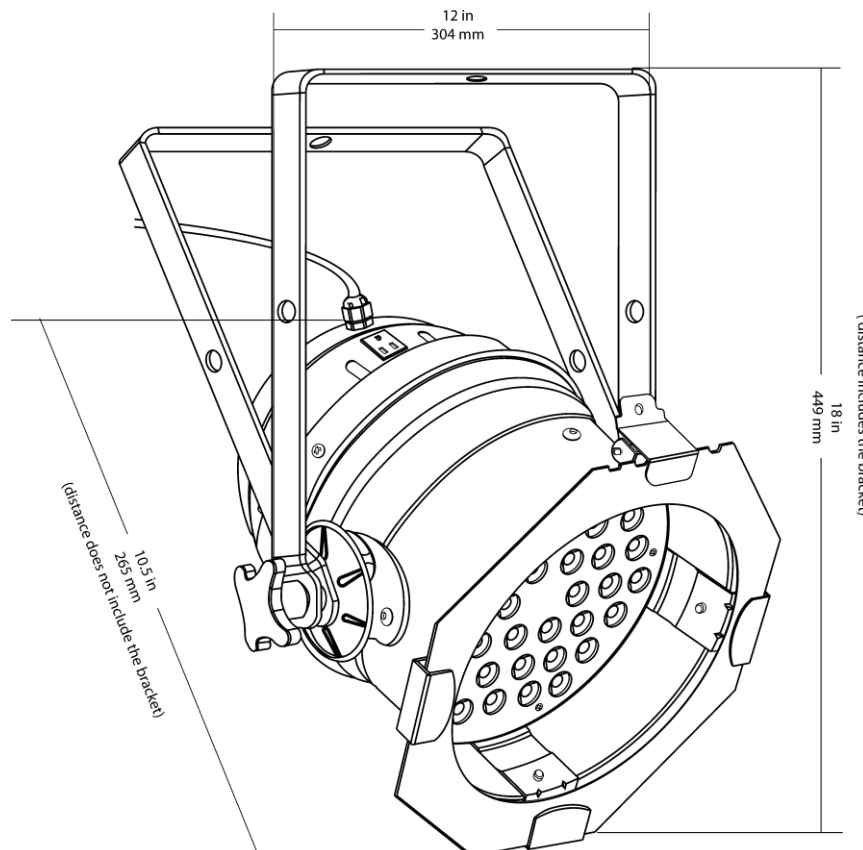

Photometrics

The photometric readings have been provided at 1 m, 3 m, and 5 m. Below, you will find a 3-dimensional drawing of the beam and field angles, along with lux and beam diameter for the field and beam angles.

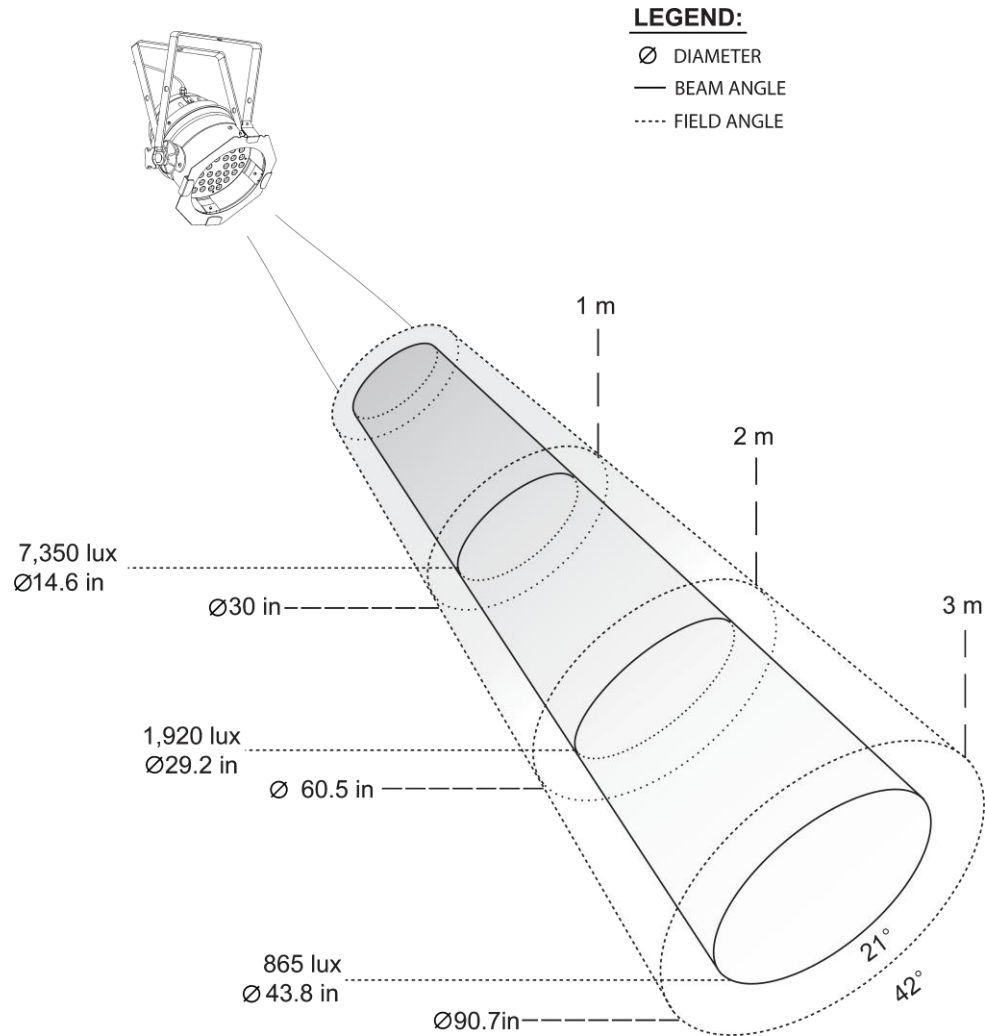

The lux measurements provided are maximum outputs at the distances stated

Product Overview

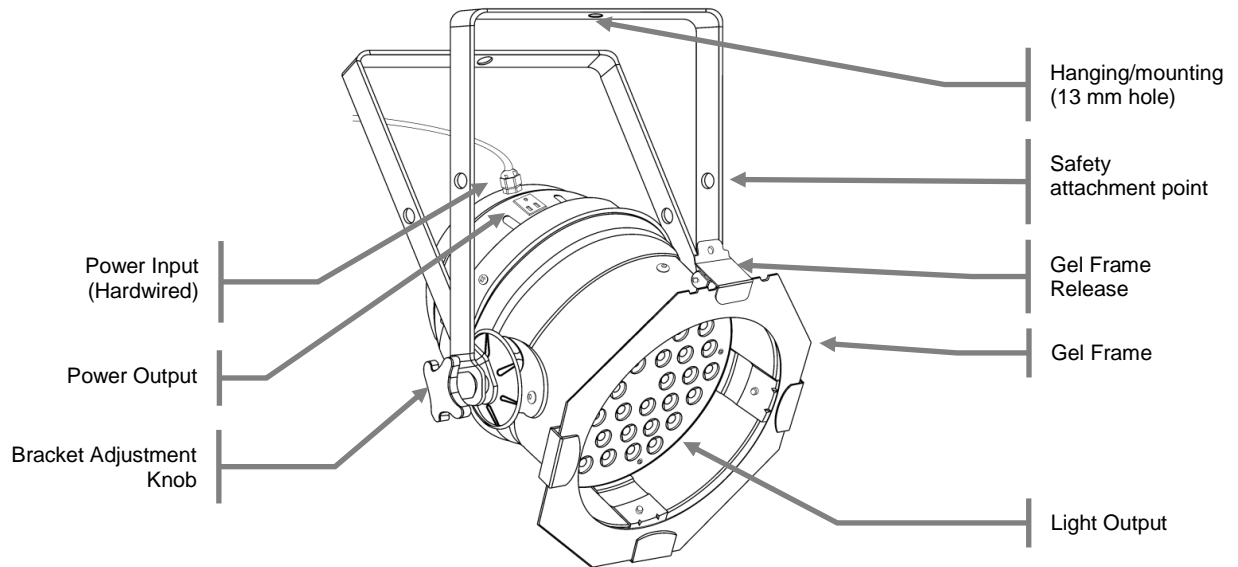
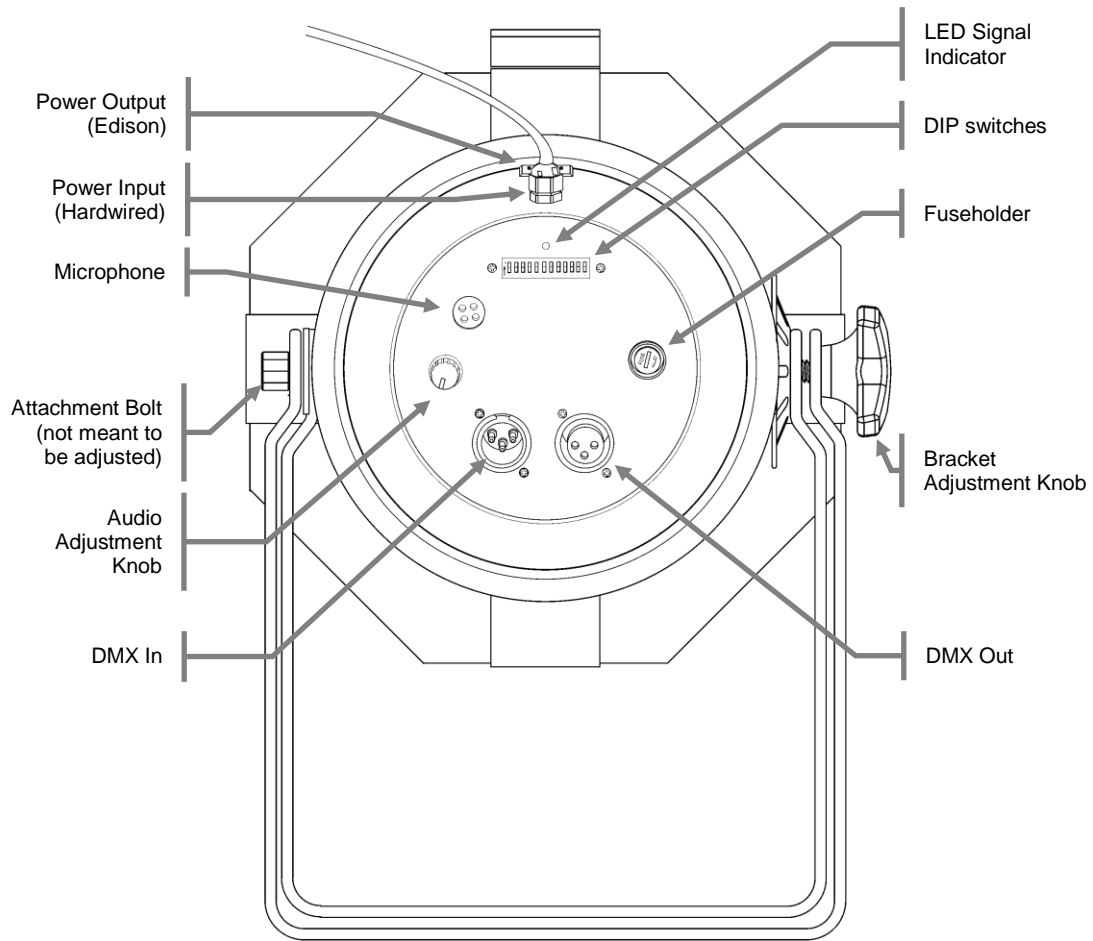

3. SETUP

AC Power

This fixture has an auto-ranging power supply which accepts an input of 100~240 VAC, 50/60 Hz. Before powering on the unit, make sure the line voltage to which you are connecting it is within the range of accepted voltages.



Always connect the fixture to a switched circuit. Never connect the fixture to a rheostat (variable resistor) or dimmer circuit, even if the rheostat or dimmer channel is used only as a 0 to 100% switch.

To determine the power requirements for a particular fixture, see the label affixed to the back plate of the fixture or refer to the fixture's specifications chart. A fixture's listed current rating indicates its average current draw under normal conditions.



Always connect the fixture to a circuit with a suitable electrical ground.

Power Linking

This fixture contains power linking via the edison outlet located in front of the power input cable. Please see the diagram below for further explanation.



The maximum quantity of fixtures that may be linked is 8.

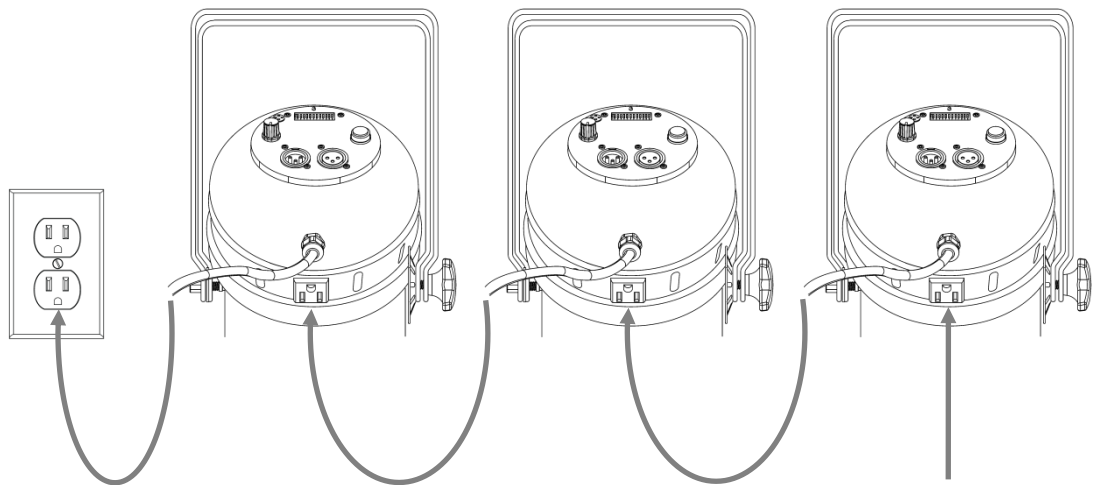

Additional power
link out

Mounting

Orientation

The LED PAR 64-36VW B/C may be mounted in any safe position provided there is adequate room for ventilation.

Rigging

Be sure that the structure can support the weight of the fixture. Please see the "Technical Specifications" section of this manual for a detailed weight listing. Mount the fixture securely. This may be done with a screw, nut and bolt, or a hanging clamp. The hole in each bracket is 13 mm in size. When rigging consider routine maintenance and control panel access. Please see the following steps for installation.

- Be sure to orient the gel frame release so that it is pointing up. Please see the diagram below for a visual reference.
- If the power link out is intended to be used with multiple fixture, take into account the length of each power cable, and mount the fixtures close enough to one another to accommodate for this.
- When aiming the fixtures, you may use the bracket adjustment knob. Loosen the knob, adjust to the desired angle, and then tighten the knob by turning clockwise. Do not use tools for this step, as it may cause damage.
- There is a secondary portion of the bracket, which may be used primarily for floor standing positions.
- Safety cables must always be used.

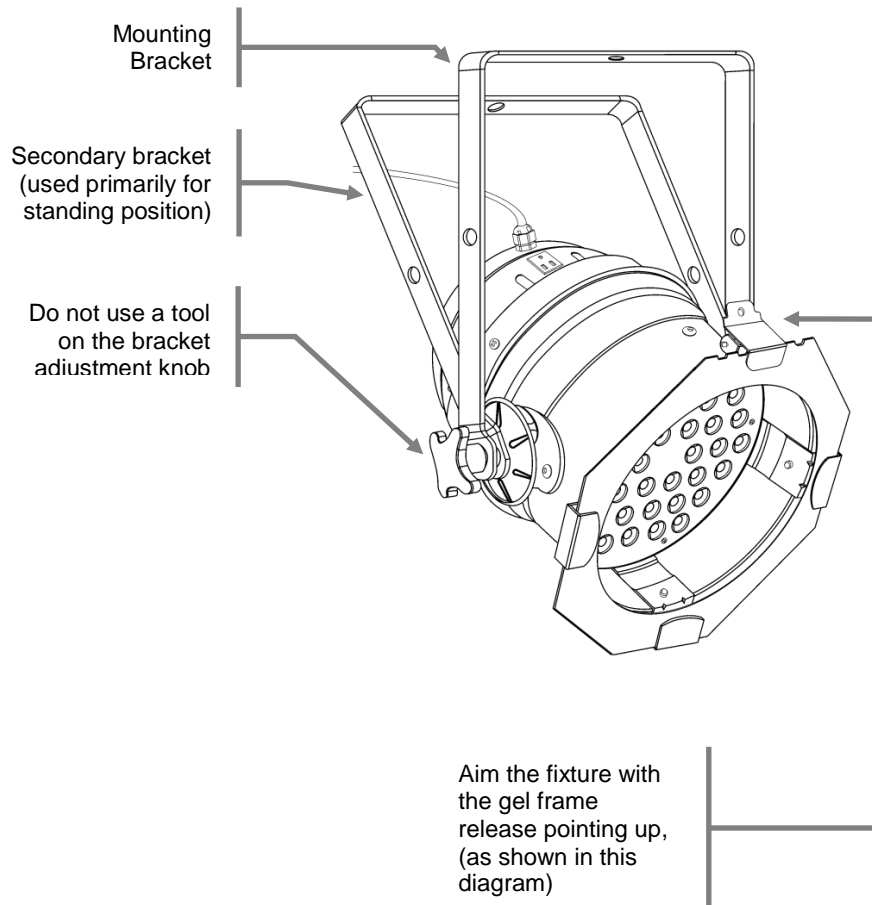

Fixture Linking

You will need a serial data link to run light shows of one or more fixtures using a DMX controller or to run synchronized shows on two or more fixtures set to a master/slave operating mode. The combined number of channels required by all the fixtures on a serial data link determines the number of fixtures the data link can support.



Fixtures on a serial data link must be daisy chained in one single line. To comply with the EIA-485 standard, no more than 32 fixtures should be connected on one data link. Connecting more than 32 fixtures on one serial data link without the use of a DMX optically-isolated splitter may result in deterioration of the digital DMX signal.

Maximum recommended serial data link distance: 500 m (1640 ft)

Maximum recommended number of fixtures on a serial data link: 32

Data Cabling

To link fixtures together you must obtain data cables. You can purchase CHAUVET® certified DMX cables directly from a dealer/distributor or construct your own cable. If you choose to create your own cable please use data-grade cables that can carry a high quality signal and are less prone to electromagnetic interference.

DMX Data Cable

Use a Belden® 9841 or equivalent cable which meets the specifications for EIA RS-485 applications. Standard microphone cables cannot transmit DMX data reliably over long distances. The cable must have the following characteristics:

Type:	shielded, 2-conductor twisted pair
Maximum capacitance between conductors:	30 pF/ft
Maximum capacitance between conductor and shield:	55 pF/ft
Maximum resistance:	20 ohms/1000 ft
Nominal impedance:	100 ~ 140 ohms

Cable Connectors

Cabling must have a male XLR connector on one end and a female XLR connector on the other end.

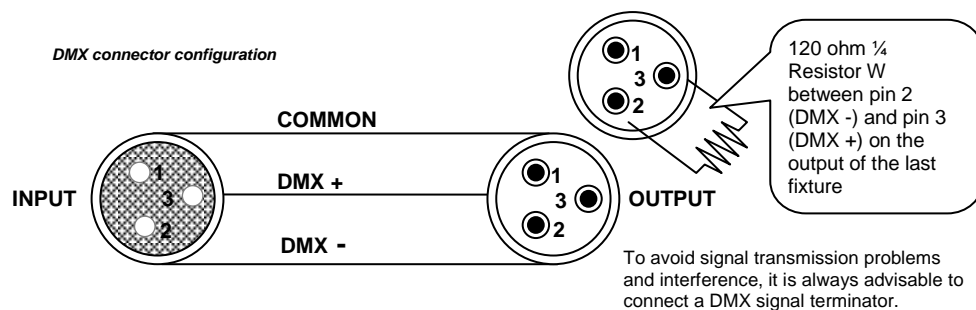

Do not allow contact between the common and the fixture's chassis ground. Grounding the common can cause a ground loop, and your fixture may perform erratically. Test cables with an ohm meter to verify correct polarity and to make sure the pins are not grounded or shorted to the shield or each other.

3-Pin to 5-Pin Conversion Chart



If you use a controller with a 5-pin DMX output connector, you will need to use a 5-pin to 3-pin adapter. The chart below details a proper cable conversion:

3-PIN TO 5-PIN CONVERSION CHART		
Conductor	3-Pin Female (Output)	5-Pin Male (Input)
Ground/Shield	Pin 1	Pin 1
Data (-) signal	Pin 2	Pin 2
Data (+) signal	Pin 3	Pin 3
Not used		Pin 4
Not used		Pin 5

Setting up a DMX Serial Data Link

1. Connect the (male) 3-pin connector side of the DMX cable to the output (female) 3-pin connector of the controller.
2. Connect the end of the cable coming from the controller which will have a (female) 3-pin connector to the input connector of the next fixture consisting of a (male) 3-pin connector.
3. Then, proceed to connect from the output as stated above to the input of the following fixture and so on.

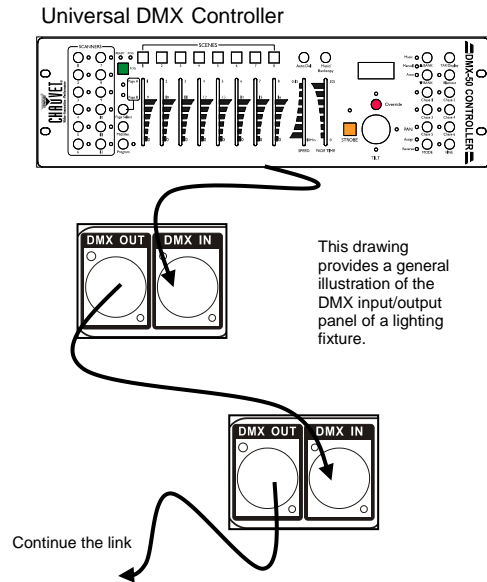

4. OPERATING INSTRUCTIONS

Configuring the Starting Address

Each fixture requires a starting address from 1~512. A fixture requiring one or more channels for control begins to read the data on the channel indicated by the starting address. For example, a fixture that uses seven DMX channels and is addressed to start on DMX channel 100, will read data from channels: 100, 101, 102, 103, 104, 105 and 106. Choose the starting addresses for each fixture so that the channels used do not overlap. In addition, you should note the starting address selected for future reference.

The LED PAR 64-36VW B/C fixture uses two or four DMX channels. If this is your first time using DMX, we recommend reading the “DMX Primer” section in the “Appendix”.

Control Panel Functions

Access control panel functions using the four buttons located directly underneath the LED display on the control panel.

BUTTON	FUNCTION
<MENU>	Used to scroll through the current operating mode, as well as back out of the current menu option
<UP>	Used to select increasing advancement in the value
<DOWN>	Used to select decreasing advancement in the value
<ENTER>	Used to select a value and store it to memory

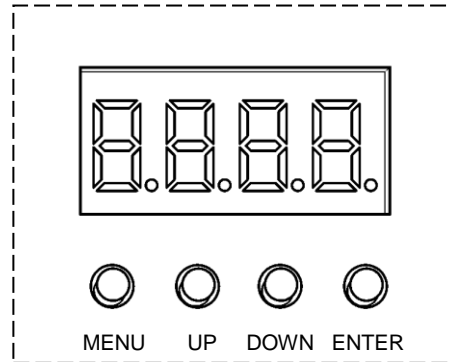

The Control Panel shows the current state of the unit. It is used to select the operating mode, as well as the sub-features. For a detailed layout of the control panel functions, please see the “menu map” section on the following page.

Menu Map

MAIN FUNCTION	SUB-FUNCTION	SELECTION	SUB-SELECTION	INSTRUCTION
P--	P1	3 Color Switching	-	Select between 1 switching and 1 fading auto programs (Use S-- to modify the speed)
	P2	3 Color fading		
	P3	3 Color Switching	<i>Use the Audio Adjustment Knob located on the back of the fixture</i>	Sound active program
2-CH	000:-05:2	-	-	Select 2-channel DMX mode: warm white, cool white
4-CH	000:-05:2	-	-	Select 4-channel DMX mode: master dimmer, warm white, cool white, strobe
C--	C1	Warm White	-	Select between 3 static colors. The display will read C1-C3. The colors that each of these represent are indicated to the left.
	C2	Cool White		
	C3	Warm and Cool White		
S--	500:-5:00 (default range is 5050)	-	-	This is the speed range for the 2 switching and fading built-in programs
U--	----	Warm White	000-100	Combine warm white and cool white to create a custom, static color
	C----	Cool White		

DMX Operation

This is the operating mode which will allow for control with an external DMX controller. You must set the starting address for this mode. If this is your first time using DMX, then it is recommended that you refer to the "DMX Primer" section in the "Appendix" of this manual.

1. Press <MENU> until 2-CH or 4-CH appears on the LED screen.
2. Press <ENTER>.
3. Using <UP> and <DOWN>, select the desired DMX address (000-05:2).

Master/Slave

This is the operating mode which will allow 1 fixture to act as the "master" and control all of the other "slave" fixtures. You must set both the master and the slave(s) fixtures to the correct mode for this operation.

Master Settings:

1. Connect the fixtures with DMX cables, as shown in the "Fixture Linking" section.
2. Use any one of the standalone modes for the master unit. This includes: P--, C--, and U--

Slave Settings:

1. Press <MENU> until 3-CH or 7-CH appears on the LED screen.
2. Press <ENTER>.
3. Using <UP> and <DOWN>, set the DMX address to 000:.



It is not necessary to set the master fixture as the first fixture in the daisy chain. It may be any fixture in the daisy chain. For example: fixture 2, 5, 10 or 12, etc.



Only 1 fixture may be set to master.



Do not connect a DMX controller to the daisy chain for this operating mode.

Standalone Operation

Automatic

This fixture has preprogrammed chases. These are accessed via the control panel, and the speed may be adjusted for the chases. Please see the instructions below for further explanation.

1. Press **<MENU>** until **P--** appears on the LED screen.
2. Press **<ENTER>**.
3. Using **<UP>** and **<DOWN>**, select the desired program (**P1-P2**).
4. Press **<ENTER>** to confirm settings.

Sound-Active

This fixture has a preprogrammed sound triggered chase. This is accessed via the control panel, and the speed may be adjusted using the audio adjustment knob. Please see the instructions below for further explanation.

1. Press **<MENU>** until **P--** appears on the LED screen.
2. Press **<ENTER>**.
3. Using **<UP>** and **<DOWN>**, select the program (**P3**).
4. Press **<ENTER>** to confirm settings.

Preset Colors

This fixture has preprogrammed static color presets. These are accessed via the control panel. Please see the instructions below for further explanation.

1. Press **<MENU>** until **C--** appears on the LED screen.
2. Press **<ENTER>**.
3. Using **<UP>** and **<DOWN>**, select the desired color preset (**C1-C3**).
4. Press **<ENTER>** to confirm settings.

Custom Static Color Mixing

This fixture has the ability to accept custom static color settings. These are accessed via the control panel. Please see the instructions below for further explanation.

1. Press **<MENU>** until **U--** appears on the LED screen.
2. Press **<ENTER>**.
3. Using **<UP>** and **<DOWN>**, select the desired color value (**000-i00**). By selecting **000**, the color will remain off.
4. Press **<ENTER>** to continue to the next color (**r, C**).
5. Using **<UP>** and **<DOWN>**, select the desired color value (**000-i00**). By selecting **000**, the color will remain off.
6. Continue until the desired mix is obtained.
7. Press **<ENTER>** to save the final color setting. This will move the selection to the following color. However, this is necessary to save the modification.

The colors are represented by the following in the menu map:

r--- = Warm White (**000-i00**)

C--- = Cool White (**000-i00**)

Fixture Linking

In order to use this fixture in a DMX or master/slave operation, you must daisy chain, using DMX cables to link from one fixture to another.

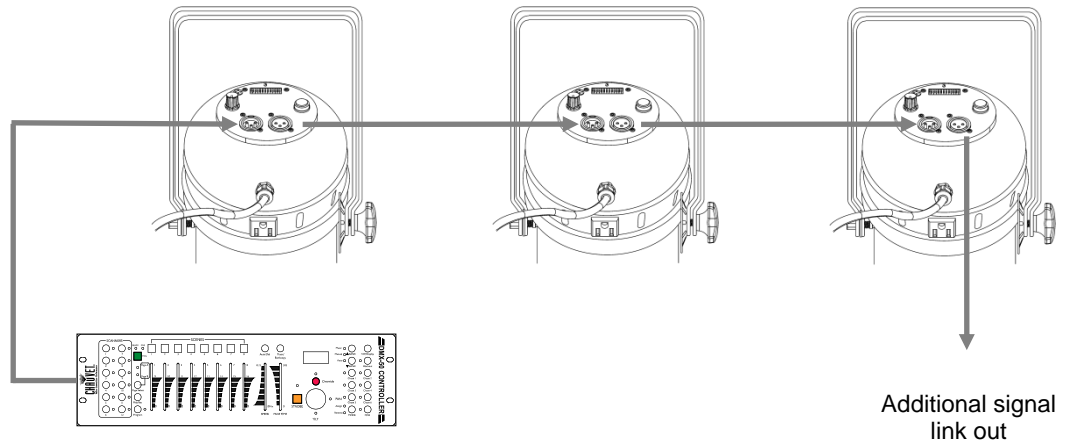

DMX Channel Values

4-CH

CHANNEL	VALUE	FUNCTION
1	000 ⇄ 255	Master Dimmer Dimmer: 0%~100%
2	000 ⇄ 255	Warm White (2900K) Dimmer: 0%~100%
3	000 ⇄ 255	Cool White (6300K) Dimmer: 0%~100%
4	000 ⇄ 015 016 ⇄ 255	Strobe No function Strobe: 0%~100%

2-CH

CHANNEL	VALUE	FUNCTION
1	000 ⇄ 255	Warm White (2900K) Dimmer: 0%~100%
2	000 ⇄ 255	Cool White (6300K) Dimmer: 0%~100%

Setting the Starting Address

This DMX mode enables the use of a universal DMX controller device. Each fixture requires a start address from 1–512. A fixture requiring one or more channels for control begins to read the data on the channel indicated by the start address. For example, a fixture that uses six DMX channels and was addressed to start on DMX channel 100, would read data from channels: 100, 101, 102, 103, 104, and 105. Choose start addresses so that the channels used do not overlap, and note the start address selected for future reference.

If this is your first time addressing a fixture using the DMX control protocol, we suggest jumping to the “Appendix” section and reading the heading “DMX Primer”. It contains very useful information that will help you understand its use.

General Troubleshooting

SYMPTOM	POSSIBLE CAUSE(S)	POSSIBLE ACTION(S)
Breaker/Fuse keeps blowing	<ul style="list-style-type: none"> Excessive circuit load Short circuit along the power wires 	<ul style="list-style-type: none"> Check total load placed on the electrical circuit. Check for a short in the electrical wiring (internal and/or external).
Device does not power up	<ul style="list-style-type: none"> No power Loose power cord 	<ul style="list-style-type: none"> Check for power on Mains. Check power cord
Fixture is not responding to DMX	<ul style="list-style-type: none"> Wrong DMX addressing Damaged DMX cables Wrong polarity settings on the controller Loose DMX cables Faulty DMX interface Faulty Main PCB 	<ul style="list-style-type: none"> Check Control Panel and unit addressing Check DMX cables Check polarity switch settings on the controller Check cable connections Replace DMX input Replace Main PCB
Loss of signal	<ul style="list-style-type: none"> Non DMX cables Bouncing signals Long cable / Low level signal Too many fixtures Interference from AC wires 	<ul style="list-style-type: none"> Use only DMX compatible cables Install terminator as suggested. Install amplifier right after fixture with strong signal. Install an optically coupled DMX splitter after unit #32. Keep DMX cables separated from power cables or black lights.



If you still have a problem after trying the above solutions, please contact CHAUVET Technical Support.

Contact Us

World Wide

General Information

CHAUVET
3000 North 29th Court
Hollywood, FL 33020
voice: 954.929.1115
fax: 954.929.5560
toll free: 800.762.1084

Technical Support

CHAUVET
3000 North 29th Court
Hollywood, FL 33020
voice: 954.929.1115 **(Press 4)**
fax: 954.929.5560 **(Attention: Service)**

World Wide Web

www.chauvetlighting.com

5. APPENDIX

DMX Primer

There are 512 channels in a DMX connection. Channels may be assigned in any manner. A fixture capable of receiving DMX will require one or a number of sequential channels. The user must assign a starting address on the fixture that indicates the first channel reserved in the controller. There are many different types of DMX controllable fixtures and they all may vary in the total number of channels required. Choosing a start address should be planned in advance. Channels should never overlap. If they do, this will result in erratic operation of the fixtures whose starting address is set incorrectly. You can however, control multiple fixtures of the same type using the same starting address as long as the intended result is that of unison movement or operation. In other words, the fixtures will be slaved together and all respond exactly the same.

DMX fixtures are designed to receive data through a serial Daisy Chain. A Daisy Chain connection is where the DATA OUT of one fixture connects to the DATA IN of the next fixture. The order in which the fixtures are connected is not important and has no effect on how a controller communicates to each fixture. Use an order that provides for the easiest and most direct cabling. Connect fixtures using shielded two conductor twisted pair cable with three pin XLR male to female connectors. The shield connection is pin 1, while pin 2 is Data Negative (S-) and pin 3 is Data positive (S+).

General Maintenance

To maintain optimum performance and minimize wear, fixtures should be cleaned frequently. Usage and environment are contributing factors in determining frequency. As a general rule, fixtures should be cleaned at least twice a month. Dust build up reduces light output performance and can cause overheating. This can lead to reduced lamp life and increased mechanical wear. Be sure to power off fixture before conducting maintenance.

- Unplug fixture from power.
- Use a vacuum or air compressor and a soft brush to remove dust collected on external vents.
- Clean all glass when the fixture is cold with a mild solution of glass cleaner or Isopropyl Alcohol and a soft lint free cotton cloth or lens tissue.
- Apply solution to the cloth or tissue and drag dirt and grime to the outside of the lens.
- Gently polish optical surfaces until they are free of haze and lint.

The cleaning of external optical lenses and/or mirrors must be carried out periodically to optimize light output. Cleaning frequency depends on the environment in which the fixture operates. Damp, smoky or particularly dirty surroundings can cause greater accumulation of dirt on the unit's optics. Clean with soft cloth using normal glass cleaning fluid. Clean the external optics at least every 20 days. Clean the fixture at least every 30/60 days.



Always dry the parts carefully after cleaning them.



Never spin a fan using compressed air.

Returns Procedure

Returned merchandise must be sent prepaid and in the original packing; call tags will not be issued. Package must be clearly labeled with a Return Merchandize Authorization Number (RMA #). Products returned without the RMA # will be refused. Call CHAUVET® and request an RMA # prior to shipping the fixture. Be prepared to provide the model number, serial number and a brief description of the cause for the return. Be sure to pack fixture properly; any shipping damage resulting from inadequate packaging is the customer's responsibility. As a suggestion, proper UPS packing or double-boxing is always a safe method to use.

CHAUVET® reserves the right to use its own discretion to repair or replace product(s).



If you are given an RMA #, please include the following information on a piece of paper inside the box:

- 1) Your name
- 2) Your address
- 3) Your phone number
- 4) The RMA #
- 5) A brief description of the symptoms

Claims

Damage incurred in shipping is the responsibility of the shipper; therefore, the damage must be reported to the carrier upon receipt of merchandise. It is the customer's responsibility to notify and submit claims with the shipper in the event that a fixture is damaged due to shipping. Any other claim for items such as missing component/part, damage not related to shipping, and concealed damage, must be made within seven (7) days of receiving merchandise.

Technical Specifications

WEIGHT & DIMENSIONS

Length..... 12 in (304 mm)
Width..... 10.5 in (265 mm)
Height..... 18 in (449 mm)
Weight..... 5.4 lbs (2.4 kg)

POWER

Auto-ranging Power Supply..... 100~240 VAC, 50/60 Hz
Power Consumption @ 120 VAC, 60 Hz..... 57 W (0.8 A) max, 0.3 A inrush
Power Consumption @ 230 VAC, 50 Hz..... 55 W (0.4 A) max, 0.3 A inrush
Power output..... 8 units max
Fuse..... T 2 A, 250 V

LIGHT SOURCE

LED..... 36 (18 warm white, 18 cool white) 1 W, 350 mA, 50,000 hrs
Color Temperature (Warm White)..... 2900K
Color Temperature (Cool White)..... 6300K

PHOTO OPTIC

Luminance @ 1 m..... 7,350 lux
Beam Angle..... 21°
Field Angle..... 42°

THERMAL

Maximum ambient temperature..... 104° F (40° C)

ORDERING INFORMATION

LED PAR 64-36VWB (Black)..... LEDPAR6436VWB
LED PAR 64-36VWC (Chrome)..... LEDPAR6436VWC

WARRANTY INFORMATION

Warranty..... 2-year limited warranty