



PRODUCT HIGHLIGHTS

- Remote-controllable 16-channel stereo digital mixer
- Channel volume and pan control with LED readout
- Dedicated Recall, Group, Solo, and Mute buttons
- Sixteen user Preset memory locations
- Master Volume, Treble, and Bass controls
- Balanced XLR and 1/4" TRS outputs
- Balanced 1/4" TRS inserts
- Auxiliary stereo mix in
- MIDI control over mix and preset save/recall
- Remote control via A-Control with the A-16CS or via RS-232 with approved third-party control systems

The A-16R Personal Mixer is a remote-controllable 16-channel stereo digital mixer. Like the industry standard A-16II, the A-16R can be used to give individual performers independent control of their monitor mixes. The A-16R is specifically designed for users of wireless in-ear-style monitors or floor wedges, and for applications where both an engineer and a performer need control over the monitor mixes.

In commercial environments, the A-16R can be effectively used in applications ranging from conferencing to room combining to simple mixing in a gymnasium or auditorium.

The A-16R provides intuitive control over volume and pan for 16 channels, as well as master volume and tone. Each A-16R can store up to sixteen preset mixes, with three subgroups per Preset. Individual channels, channel pairs, or groups can be soloed or muted.

The A-16R can be controlled remotely from the optional A-16CS Control Surface or by select third-party controllers and touch panels. Remote control allows the A-16R to be placed in an equipment rack with other gear, such as amps or transmitters, while still allowing a user

to control the mix. The A-16CS is connected to the A-16R with a single Cat-5e cable, up to 200ft (60m).

The A-16R provides balanced line-level outputs on XLR or 1/4" TRS jacks. Insert send and return points are provided via balanced 1/4" TRS jacks. MIDI In, Out, and Thru jacks provide the ability to save/load settings or select A-16R presets via MIDI. An auxiliary stereo mix input supports input of local audio such as a click track.

Audio is provided to the A-16R on a Cat-5e cable via Aviom's ultra-fast Pro16® A-Net® protocol. Pro16 A-Net supports plug-and-play set-up, long cable runs (up to 500ft/150m between devices), and 24-bit uncompressed digital audio. Mixers can be connected in series or in parallel, using the A-16D or A-16D Pro A-Net Distributor. Power can be supplied locally with an external DC power supply or remotely, over the Cat-5e cable, using an A-Net Distributor.

The A-16R Personal Mixer can be used in virtually any combination with other Pro16 devices. There is no limit to the number of Personal Mixers that can be used in a system.

A-16R PERSONAL MIXER SPECIFICATIONS

Audio Outputs	Impedance matched output
Headphone Output	Front panel; TRS; Tip: Audio Left; Ring: Audio Right; Sleeve: Ground
Mix input, stereo	Balanced 1/4" TRS; front-panel volume control
Insert send/return	Balanced 1/4" TRS
A-Net I/O	1 A-Net In, 1 A-Net Out; RJ45 connectors
D/A Conversion	44.1/48kHz, 24-bit
Indicators	Pan: 5 LEDs, 4 red, 1 green; Channel Volume: 12 red LEDs
Stereo Operation	Stereo Link, per channel pair; set at the input module Variable pan/spread per channel or channel pair
Tone Controls	Treble: +/-12dB at 9kHz shelving Bass: +/-12dB at 160Hz shelving
Output Impedance	140 ohms
Freq. Response	4Hz-22kHz +0.2dB/-3dB
THD +N	<0.003%
Signal to Noise (unweighted)	-90dB typical, A/D to D/A Measured from AN-16/i to A-16II

Crosstalk	-90dB
Latency	0.880 msec (measured from analog input to analog output)
A-Net Pro16	uses unshielded Cat-5e UTP (or better) cable; maximum 500ft (150m) between devices
Remote Control	A-16CS: A-Control, RJ45 jack, max. 200 ft (60m) Compatible with select third-party controllers
Power Supply	External, DC, universal switching type Input Voltage: 100-240 volts, 50/60Hz, 30VA Output Voltage: 18-24 VDC, 0.5 amp Plug Size: 2 mm
Dimensions, A-16R	19" (482.6 mm) x 6.7" (170.2 mm) , 1U high
Dimensions, A-16CS	10.75" (273 mm) x 5.6" (142.2 mm); 2.25" (57.5 mm) high
Weight	3.4 lbs (1.54 kilo)
Options	A-16CS Control Surface MT-1 Mic Stand Bracket (for A-16CS) EB-1 Extension Bracket
<i>All Aviom products are designed and manufactured in the USA.</i>	

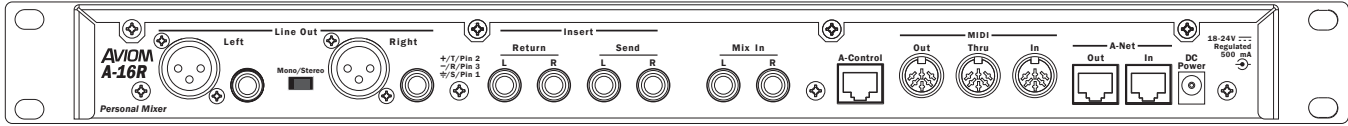

A-16R REAR PANEL FEATURES

- Balanced audio outputs
- Mono/Stereo switch
- Insert Send/Return
- Aux Mix In
- A-Control (to remote controller)
- MIDI In, Out, Thru
- A-Net In, A-Net Out
- DC power

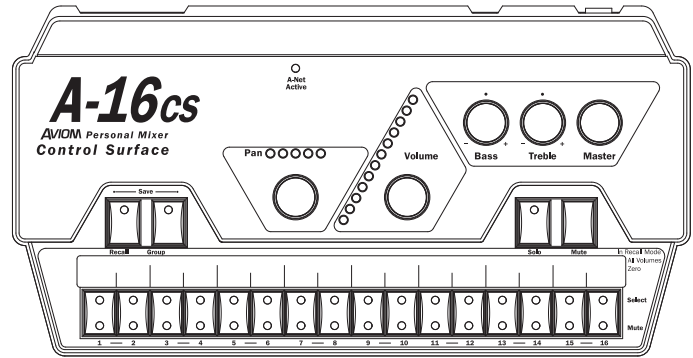

The optional A-16CS Control Surface allows the A-16R to be controlled from up to 200ft (60m) away.

A-16R BLOCK DIAGRAM

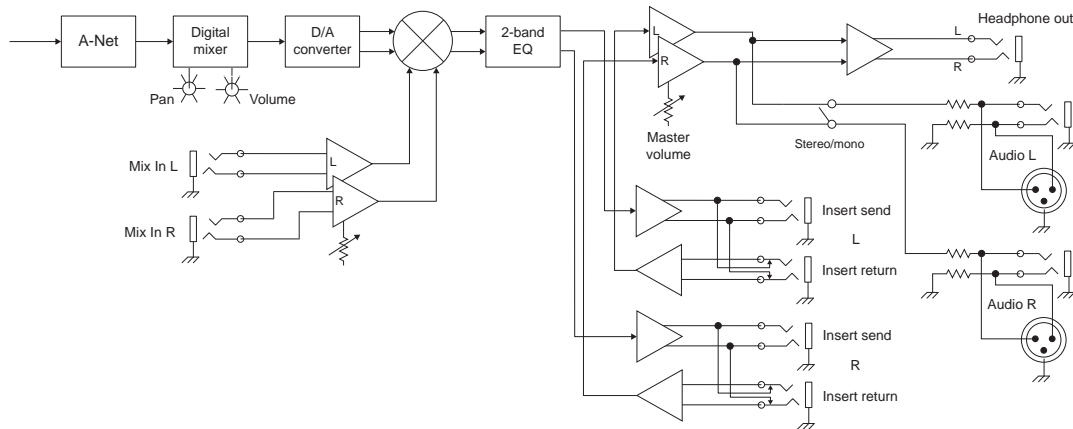

ARCHITECTURAL SPECIFICATION

The Aviom A-16R Personal Mixer shall provide stereo mixing for sixteen channels of audio transmitted via an A-Net Pro16 network over Cat-5e UTP cable. It shall provide full-bandwidth, high-quality audio by employing the Aviom A-Net Pro16 audio transmission protocol. It shall employ 24-bit D/A converters with a 44.1/48kHz sampling rate.

The audio output shall be capable of being connected to headphones or line-level audio sources. Output impedance shall be 140 ohms. Maximum level (RMS) shall be 1.0 watt at 100 ohms.

Front panel features shall include master volume, treble and bass controls, LED indicators for channel volume and pan, lighted channel-select buttons, mute and solo functions, Mix In volume control, and a 1/4" TRS stereo headphone output with level control. The unit shall be capable of storing sixteen mixes as presets in internal memory, as well as externally via MIDI. A front-panel switch shall be provided to select local or remote operation.

The unit shall be powered from an external universal power supply (input voltage 100 to 240 VAC; output voltage 18-24 VDC, 0.5 amps) and shall include a detachable DC power cord. It shall be UL and CE listed.

The A-16R rear panel shall have RJ45 connectors for A-Net digital signal input and output, and 5-pin DIN jacks for MIDI in, out, and thru. The unit shall employ parallel balanced XLR and 1/4" TRS jacks for line-level outputs, a stereo/mono switch, balanced 1/4" TRS insert send and return jacks, and stereo auxiliary mix inputs with balanced 1/4" TRS jacks. One RJ45 jack shall be supplied for connection of an optional wired remote control, the A-16CS Control Surface.

Its dimensions shall be 19 inches wide, 6.7 inches deep, and 1.75 inches (1U) high. Its net weight shall be 6.8 pounds, and its steel chassis shall be finished in blue. The unit shall be Aviom, Inc. model A-16R.

The A-16CS Control Surface shall provide remote operation of mix parameters of the A-16R Personal Mixer, when connected via Cat-5e cable to the A-Control port of the A-16R. The user interface of the A-16CS shall be functionally similar to that of the A-16I.

The A-16CS rear panel shall have one RJ45 jack for connection to the A-Control port of the A-16R host, which also supplies power to the A-16CS. Its dimensions shall be 10.75 inches wide, 5.6 inches deep, and 2.25 inches high. Its net weight shall be 3.4 pounds, and it shall be finished in blue. The unit shall be Aviom, Inc. model A-16CS.